



Acousto-Optic Deflector Driver

Including: Basic Deflector Alignment

Instruction Manual

630c Series – Analog Modulation

Key to model types : **630C-fff-m**

Base model features 1.0Vpp, 50ohm modulation input level and 24/28Vdc supply.

'C' indicates case style

'fff' indicates centre frequency of tuning range

27	:	19-35	MHz
40	:	30-50	MHz
80	:	60-100	MHz
100	:	75-125	MHz
110	:	80-140	MHz
150	:	100-200	MHz
200	:	150-250	MHz
350	:	250-450	MHz

and where appended,

'm' indicates options (combinations possible)

V	:	5.0V Modulation Input
L	:	+15V supply operation
B	:	Modulation biased On

1. GENERAL

The 630c series Modulator/Deflector Driver, figure 1, is a modular, swept-frequency RF power source specifically designed to operate with Isomet acousto-optic deflectors (scanners). The driver accepts a tuning voltage between approximately +0 volts and +10 volts and provides an RF output to the acousto-optic deflector at the tuned frequency. The driver also accepts an analogue modulating signal at baseband video frequency and provides a double-sideband amplitude modulated RF output to the acousto-optic deflector. Examples of popular driver specifications are listed below:

Model

630c-100	: 75-125MHz, 1.8W output, 1.0V Modulation Input, +24Vdc supply
630c-200	: 150-250MHz, 1.6W output, 1.0V Modulation Input, +24Vdc supply
630c-350	: 250-450MHz, 0.7W output, 1.0V Modulation Input, +24Vdc supply

Figure 2 is a block diagram of the 630c Driver. The output frequency of the driver is controlled by a hybridized varactor oscillator circuit. The capacitance of the internal varactor is a function of the applied tuning voltage. The output frequency is proportional to the input tuning voltage with a scale factor of approximately 10.0 MHz/volt. The start frequency corresponding to a tuning voltage of 0.0 volts is defined by the frequency offset potentiometer (FOS). This permits adjustment of the start frequency from approx -10% / +50%. A table of output frequency versus input tuning voltage is supplied with each driver; a typical voltage vs. frequency curve is shown in figure 4. The frequency linearity is typically $\pm 1.5\%$, and frequency stability is typically $\pm 0.25\%$.

The oscillator output is connected to a matched RF splitter. This provides buffered signals to a diode ring RF modulator and the frequency monitor output. The frequency monitor output provides a low level (approx. 300mVpp) output signal at the tuned operating frequency. This can be used for measurement or feedback purposes.

The high-frequency, diode ring modulator is used to amplitude-modulate the RF carrier. A modulation input swing of 1 volt peak to peak (positive or negative with respect to ground) will result in 100% depth of modulation. The input level must not exceed 5 volts peak to peak ($\pm 2.5V$ with respect to ground).

(Note: For the 630c-fff-V types the respective levels are ; 5 volt input swing and ± 10 volt maximum)

The output hybrid amplifier is designed to operate at full rated power into a 50Ω load with 100% duty cycle. The output power level is set by the power adjust potentiometer at the input of the hybrid amplifier.

Figure 3 illustrates the principal waveforms of the 630c series Driver.

Conduction cooling of the driver from the mounting face to a heat sink or forced-air convection cooling is mandatory. The mounting face temperature must not exceed 70°C.

**SERIOUS DAMAGE TO THE AMPLIFIER MAY RESULT IF THE TEMPERATURE EXCEEDS 70°C.
SERIOUS DAMAGE TO THE AMPLIFIER MAY ALSO RESULT IF THE RF OUTPUT CONNECTOR
IS OPERATED OPEN-CIRCUITED OR SHORT-CIRCUITED.**

All 630c series drivers require a stable d-c power for operation. The required voltage is +24Vdc (+28Vdc maximum) at a current drain of approximately 550mA EXCEPT model 630c-L. This lower power driver operates from 15Vdc. The external power source should be regulated to ± 2% and the power supply ripple voltage should be less than 100mV for best results.

2. SPECIFICATIONS

Oscillator Type:	Varactor-tuned thin film hybrid
Amplifier Type:	Broadband Class A
Output RF Power:	\geq Watt (See specific driver test data sheet)
Output Impedance:	50 Ω nominal
Load VSWR:	< 2.5:1 for best results
Output RF Power Variation vs. Frequency	\leq 1 dB
Spurious Outputs:	Harmonics > 20dB below fundamental
Tuning Range:	Model specific
Tuning Voltage:	0 to 10V for specified tuning range
Tuning Linearity:	< +/- 1.5% over specified tuning range

**DO NOT APPLY NEGATIVE TUNING VOLTAGE
DO NOT EXCEED + 20V INPUT
DAMAGE MAY RESULT**

Tuning Voltage Impedance:	Drive from low impedance source, 50 Ω or less
Tuning Slew Rate	> 10 MHz/ μ s
Residual FM:	< 10 KHz peak-to-peak
Frequency Stability:	\pm 0.25%
Video (MOD) Input Voltage:	1V peak-to-peak for 100% depth of modulation, DC coupled
Mod Input Impedance:	50 Ω source
RF ON-OFF Ratio:	> 37 dB (except 630C-350)
DC Power Input:	+24VDC at < 600 mA regulated to \pm 1%
Temperature Range:	0°C to 60°C ambient, temperature at mounting face must not exceed 70°C
Mounting Orientation:	Any

3. THEORY OF OPERATION

Figure 5 illustrates the key operating parameters. Further explanation is given in the accompanying application notes 'Acousto Optic Deflectors'.

4. INSTALLATION AND ADJUSTMENT

a. Install the 630c Driver on a heat sink. Use heat conducting compound between the Driver mounting face and the heat sink.

b. With no d-c power applied, connect the + 24Vdc line to the centre terminal of the feed-thru terminal as shown in Figure 1. DO NOT APPLY POWER UNTIL THE LOAD IS CONNECTED.

c. Align the deflector head to insure that the incident light beam is centred in the active aperture of the deflector. The following explanation assumes the light beam is directed slightly toward the transducer (connector end) of the deflector.

[Note: Off-axis AO deflectors i.e. models OADxxx are design to operate in a specific orientation. See data sheet for guidance]

d. Connect the SMA connector of the deflector to the 'RF' output of the 630c driver (SMA).

e. Connect a low impedance source to the SMA modulation input 'MOD' and adjust to give a constant dc input level of 1.0V. (5.0V for –V versions)

f. Connect the tuning voltage source to the SMA tuning voltage input 'Vt'.

To begin, apply a constant voltage of 5V equivalent to the centre frequency.

The start point of the input tuning voltage can be adjusted by means of the 'FOS' adjustment pot'.

Clockwise rotation of the FOS pot' increases the start frequency.

The output frequency can be measured by connecting a frequency counter to the 'Fmon' output SMC connector.

g. Start by rotating the Power Adjust potentiometer by fully anti-clockwise. This will give minimum output. The RF power increases with clockwise rotation of the pot.

This is a 24-turn pot.

h. Apply approximately half the required RF power (say 0.3 - 0.4W) at the centre frequency.

For the Isomet 630c this is achieved by adjusting the 5 – 10 turns clockwise from the fully anti-clockwise position. Turn on DC power.

Rotate the deflector slightly until deflection of the light beam occurs. The deflection will occur in the horizontal plane. Select the diffraction spot next to the undiffracted beam and monitor the light intensity by using either a photodetector or a light power meter. Re-adjust the Bragg angle for maximum deflected light intensity. Fine tuning of the incident light beam position may be necessary for optimum results.

- i. Adjust RF power level carefully for the desired efficiency at the minimum RF power necessary. Do NOT exceed the RF power level at which maximum efficiency is achieved (P_{sat}). Over driving the AO deflector will reduce efficiency and may result in serious damage to the AO crystal.

- j. To equalise deflection efficiency at the extremes of the scan, alternate between the minimum and maximum desired frequencies and adjust Bragg angle to give the same efficiency for both. (Note: the photo detector or light power meter will require repositioning for the two angles).

- k. Under some circumstances, the RF driver maximum output power will be less than the AO device optimum operating point e.g. at longer NIR wavelengths. In such cases, the diffraction efficiency roll-over point will not be observed as the RF power is increased.

5. THERMAL EFFECTS

We must consider the thermal effects of this device - both due to optical and acoustic absorption.

The majority of heat is generated by RF drive power. As the temperature of the material increases beyond the recommended level, undesired refractive index changes will occur in the material. This results in beam distortion. Ultimately, the crystal will crack due to thermal stresses, if excessive RF power is applied. (>2.0W for a typical visible AO deflector).

6. MAINTENANCE

6.1 Cleaning

It is of utmost importance that the optical apertures of the deflector optical head be kept clean and free of contamination. When the device is not in use, the apertures may be protected by a covering of masking tape. When in use, frequently clean the apertures with a pressurized jet of filtered, dry air.

It will probably be necessary in time to wipe the coated window surfaces of atmospherically deposited films. Although the coatings are hard and durable, care must be taken to avoid gouging of the surface and residue of the cleaning solution. It is suggested that the coatings be wiped with a soft ball of brushed (short fibres removed) cotton, slightly moistened with clean alcohol. Before the alcohol has had time to dry on the surface, wipe again with dry cotton in a smooth, continuous stroke. Examine the surface for residue and, if necessary, repeat the cleaning.

6.2 Troubleshooting

No troubleshooting procedures are proposed other than a check of alignment and operating procedure. If difficulties arise, take note of the symptoms and contact the manufacturer.

6.3 Repairs

In the event of deflector malfunction, discontinue operation and immediately contact the manufacturer or his representative. Due to the high sensitive of tuning procedures and the possible damage which may result, no user repairs are allowed. Evidence that an attempt has been made to open the optical head will void the manufacturer's warranty

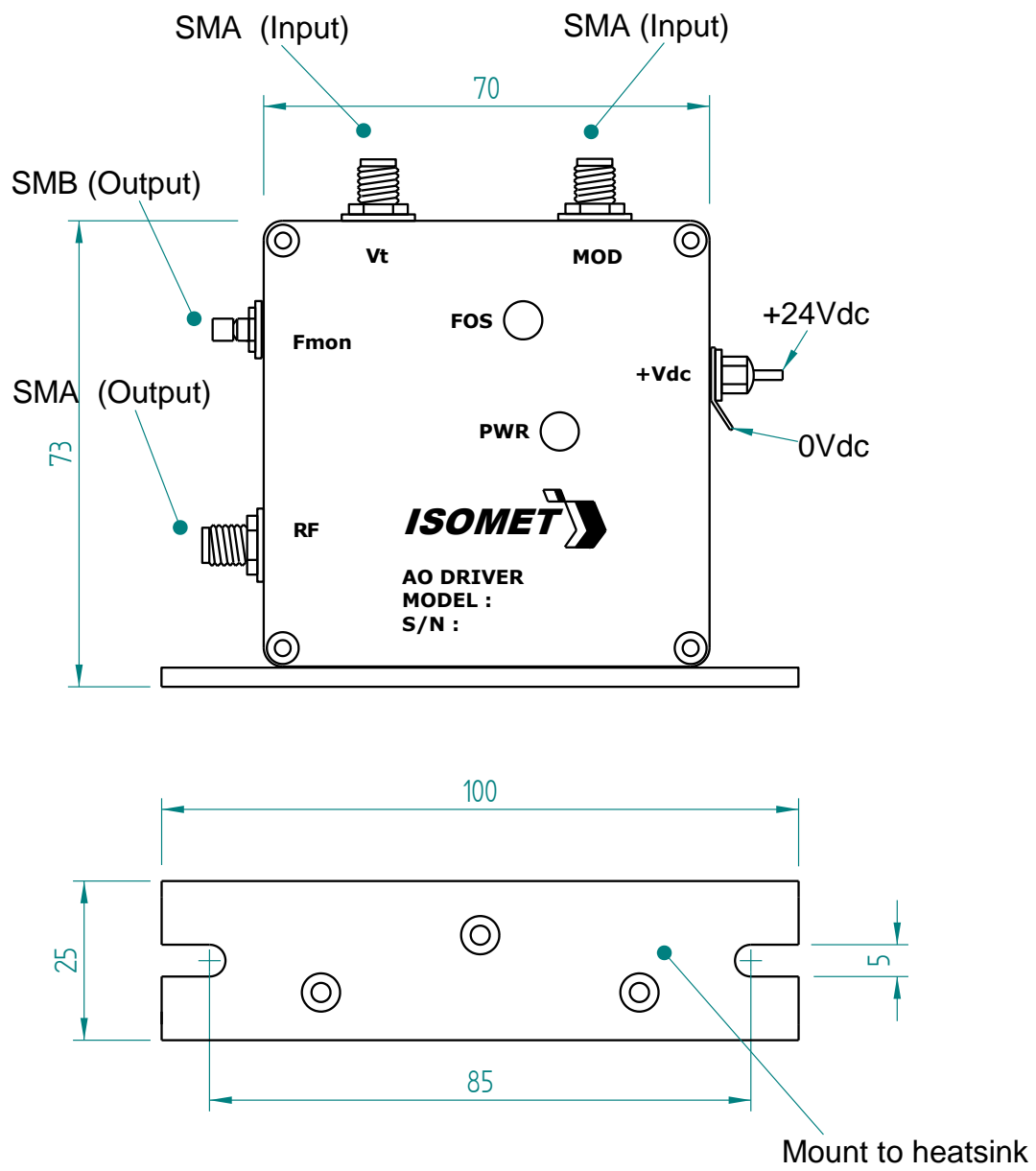

Figure 1, Driver Installation

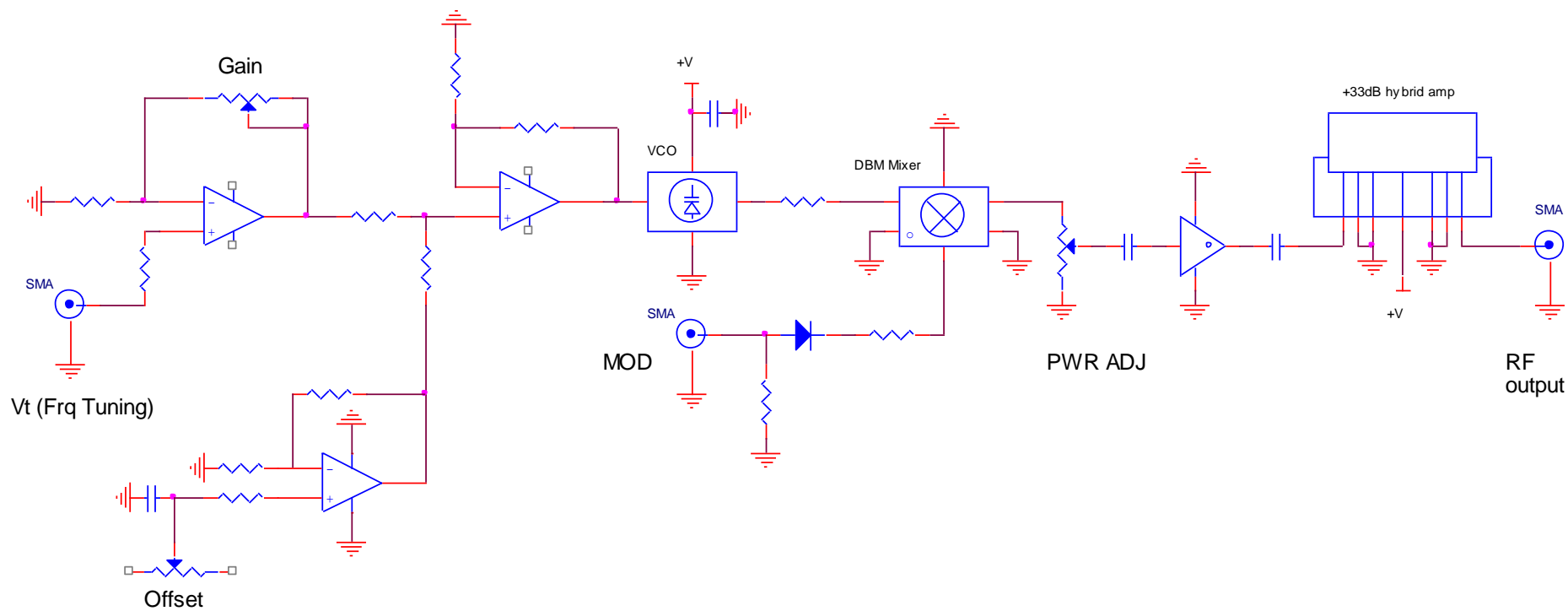

Figure 2, Driver Block Diagram

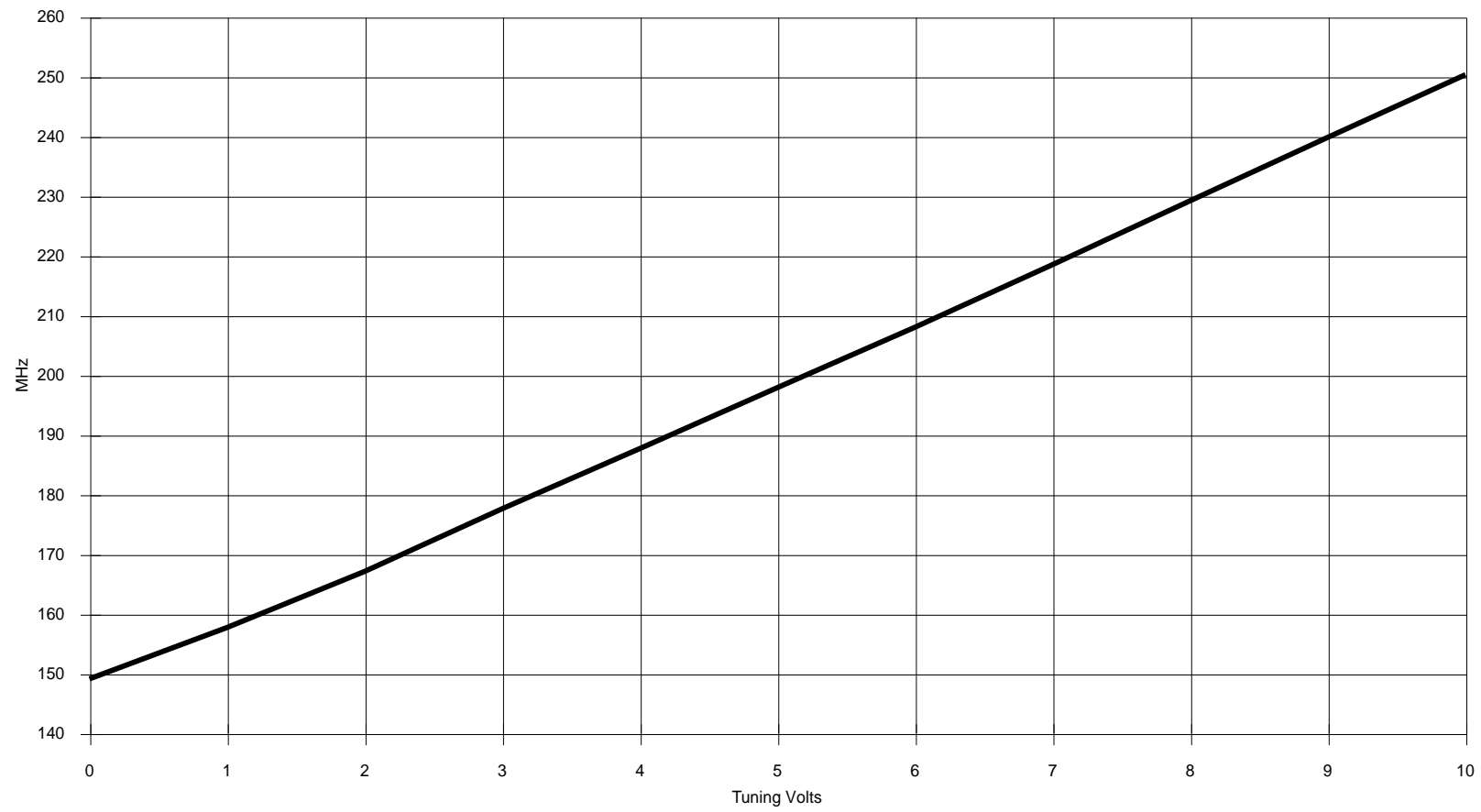
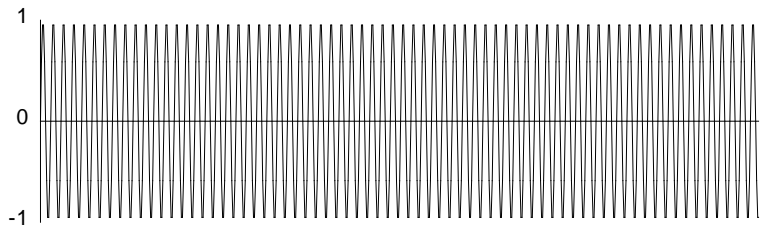
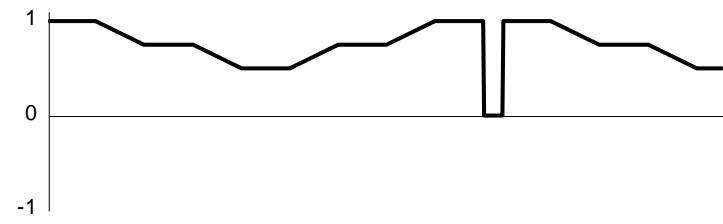

Figure 4, Typical 630c-200 Tuning Characteristic



RF Carrier



Video Input

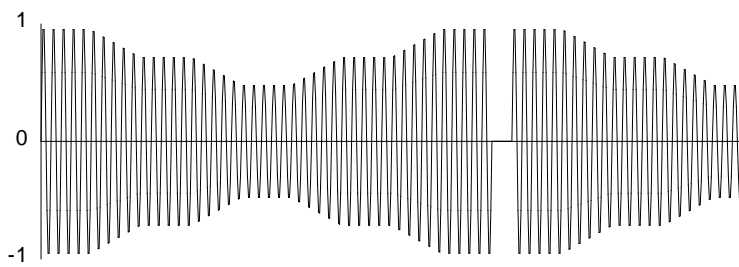

Modulated RF

Figure 3, Typical Waveforms

Schematic of a single electrode acousto optic deflector and tunable driver

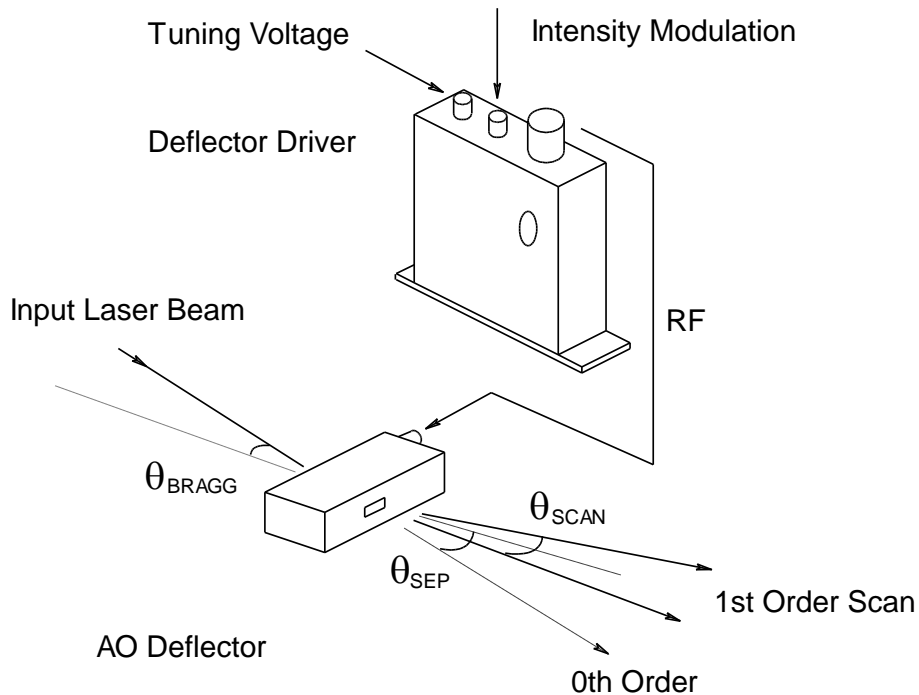

The input bragg angle, relative to a normal to the optical surface and in the plane of deflection is :

$$\theta_{BRAGG} = \frac{\lambda \cdot fc}{2 \cdot v}$$

The separation angle between the zeroth order and mid scan point of the first order is :

$$\theta_{SEP} = \frac{\lambda \cdot fc}{v}$$

The first order scan angle is :

$$\theta_{SCAN} = \frac{\lambda \cdot \delta f}{v}$$

where :

λ	=	wavelength
δf	=	scan frequency bandwidth
fc	=	centre frequency
v	=	acoustic velocity of interaction material

Figure 5,