



Acousto-Optic Modulator Driver

Including: Basic Modulator Alignment

Instruction Manual

720c Series – Digital Modulation, >60dB RF contrast ratio

Key to model types : **72o.C-m-ff**

Base model features TTL buffer compatible modulation input level and 24/28Vdc supply.

'o' indicates the base models standard frequency

1	:	40MHz
2	:	80MHz
3	:	110MHz
4	:	150MHz
5	:	200MHz

'C' indicates case style

and where appended,

'm' indicates options (combinations possible)

2	:	2 Watt output
4	:	4 Watt output
6	:	6 Watt output
L	:	+15V supply operation

'ff' indicates non-standard frequency e.g.

50	:	50MHz
120	:	120MHz

ISOMET CORP, 5263 Port Royal Rd, Springfield, VA 22151, USA.

Tel: +1 703 321 8301, Fax: +1 703 321 8546, e-mail: isomet@isomet.com

www.ISOMET.com

ISOMET (UK) Ltd, 18 Llantarnam Park, Cwmbran, Torfaen, NP44 3AX, UK.

Tel: +44 1633-872721, Fax: +44 1633 874678, e-mail: isomet@isomet.co.uk



1. GENERAL

The 720c series Analog Driver is a fixed frequency RF power source specifically designed for use with Isomet acousto-optic modulators and Q-switches, operating at a fixed centre frequency. The driver accepts an digital (On:Off) modulating signal at baseband video frequency and provides a double-sideband amplitude modulated RF output to the acousto-optic modulator. Examples of popular driver specifications are listed below:

Model

721c-2	: 40MHz, 3.0W output, +24Vdc supply
722c-2	: 80MHz, 2.8W output, +24Vdc supply
723c-2	: 110MHz, 2.0W output, +28Vdc supply

Figure 2 is a block diagram of 720c series driver. The center frequency of the driver is determined by the free-running quartz-crystal oscillator. This frequency is accurate to within $\pm 0.005\%$ and its stability is better than $\pm 0.003\%$; the oscillator is not temperature stabilized.

A high-frequency, diode ring mixer and RF analog switch are used to modulate the RF carrier according to the signal applied to the driver MOD (Video) input. A video input swing from $< 0.6V$ (off) to > 2.7 volt(on) will result in 100% depth of modulation.

The combination of mixer and analog switch provides the high On:Off RF output ratio of $> 60dB$.

The modulation input level must not exceed + 7 volts

The mixer output is applied to a MMIC pre-amplifier stage. This also serves to isolate the Oscillator and Mixer from the final power amplifier stage. The driver output power level is set by the Power adjust potentiometer at the input of this MMIC amplifier.

The amplitude-modulated MMIC output drives the input to a DMOS FET based power amplifier. This amplifier is designed to operate at full rated power into a 50Ω load with 100% duty cycle.



Figure 3 illustrates the principal waveforms of the 720c Driver.

Conduction cooling of the driver from the mounting face to a heat sink or forced-air convection cooling is mandatory. The mounting face temperature must not exceed 70°C.

SERIOUS DAMAGE TO THE AMPLIFIER MAY RESULT IF THE TEMPERATURE EXCEEDS 70°C. SERIOUS DAMAGE TO THE AMPLIFIER MAY ALSO RESULT IF THE RF OUTPUT CONNECTOR IS OPERATED OPEN-CIRCUITED OR SHORT-CIRCUITED.

All 720c series drivers require a stable d-c power for operation. The required voltage is +24 / 28Vdc at a current drain of approximately 470mA EXCEPT model 720c-L. This lower power driver operates from 15Vdc. The external power source should be regulated to $\pm 2\%$ and the power supply ripple voltage should be less than 25mV for best results.

2. DIGITAL MODULATION

The 720 Series Modulator Driver, features one control for the RF POWER ADJUST. The RF POWER ADJUST control sets the peak driver output for the ON condition (TTL=1). A low level input (TTL=0) will turn the RF output OFF.



3. INSTALLATION AND ADJUSTMENT

- 3.1 Install the Driver on a heat sink as shown in figure 1. Use heat conducting compound between the Driver and mounting face and the heat sink.
- 3.2 With no d-c power applied, connect the positive (+) DC to the center terminal of the feed-thru terminal as shown in figure 1. Connect the 0V or ground connection to the earth tab.
DO NOT APPLY POWER.

The standard 72xC-2 models are internally regulated and can accept a wide supply voltage range of between +22V to +28Vdc, with no change in RF power.

For the higher power types 720C-4, or -6, the output power is supply dependent - see test data sheet supplied with unit.

DO NOT EXCEED +28Vdc or apply reverse polarity.

Also for the lower power type 720C-L, the output power is supply dependent.

DO NOT EXCEED +15Vdc or apply reverse polarity.

- 3.3 Connect the RF output SMA jack to an acousto-optic modulator (or 50Ω RF load, if it is desired to measure the modulator RF output power).
- 3.4 Connect a TTL signal source to the modulation 'MOD' input SMB jack
- 3.5 Adjustment of the RF output power is best done with Driver connected to the acousto-optic modulator. The Driver maximum output power is factory preset to a nominal level of approximately half maximum power.

The optimum RF power level required for the modulator to produce maximum first order intensity will be different at various laser wavelengths. Applying RF power in excess of this optimum level will cause a decrease in first order intensity (a false indication of insufficient RF power) and make accurate Bragg alignment difficult. It is therefore recommended that initial alignment be performed at a low RF power level.



- 3.6 If fitted, remove the PWR ADJ snap-in plugs from the driver case (see fig 1).
The PWR ADJ pot is a multi-turn type. Minimum power is when fully anti-clockwise (CCW).
With an insulated alignment tool or screwdriver:
Rotate the PWR ADJ potentiometer CCW at least 11 turns, then CW approx 5 turns.
- 3.7 Apply +15V, + 24V, or +28V DC power to the driver as appropriate for the model.
(see Section 1 and driver test sheet)
- 3.8 Apply a constant 'High' TTL input level ($> 2.7V$, 15mA drive capability).
- 3.9 Observe the diffracted first-order output from the acousto-optic modulator and the undeflected zeroth order beam. Adjust the Bragg angle (rotate the modulator) to maximise first order beam intensity.

Note: the diffraction efficiency may not exceed 20-30% at this point in the alignment procedure.
- 3.10 After the Bragg angle has been optimised, slowly increase the RF power (rotate PWR ADJ CW) until maximum first order intensity is obtained. This peaked RF drive level is termed the saturation power; P_{sat} . For applications using a well focussed input beam into the AOM, the correctly adjusted Bragg angle condition is indicated when the zero order shows a characteristic dark line through the middle of the beam at or near the P_{sat} drive level.

The driver is now ready for use as a digital modulator. Connect the desired TTL drive source to the (Video) MOD input SMB jack.

The video input must not exceed 7V peak.



4. MAINTENANCE

4.1 Cleaning

It is of utmost importance that the optical apertures of the deflector optical head be kept clean and free of contamination. When the device is not in use, the apertures may be protected by a covering of masking tape. When in use, frequently clean the apertures with a pressurized jet of filtered, dry air.

It will probably be necessary in time to wipe the coated window surfaces of atmospherically deposited films. Although the coatings are hard and durable, care must be taken to avoid gouging of the surface and residue of the cleaning solution. It is suggested that the coatings be wiped with a soft ball of brushed (short fibres removed) cotton, slightly moistened with clean alcohol. Before the alcohol has had time to dry on the surface, wipe again with dry cotton in a smooth, continuous stroke. Examine the surface for residue and, if necessary, repeat the cleaning.

4.2 Troubleshooting

No troubleshooting procedures are proposed other than a check of alignment and operating procedure. If difficulties arise, take note of the symptoms and contact the manufacturer.

4.3 Repairs

In the event of deflector malfunction, discontinue operation and immediately contact the manufacturer or his representative. Due to the high sensitive of tuning procedures and the possible damage which may result, no user repairs are allowed. Evidence that an attempt has been made to open the optical head will void the manufacturer's warranty.

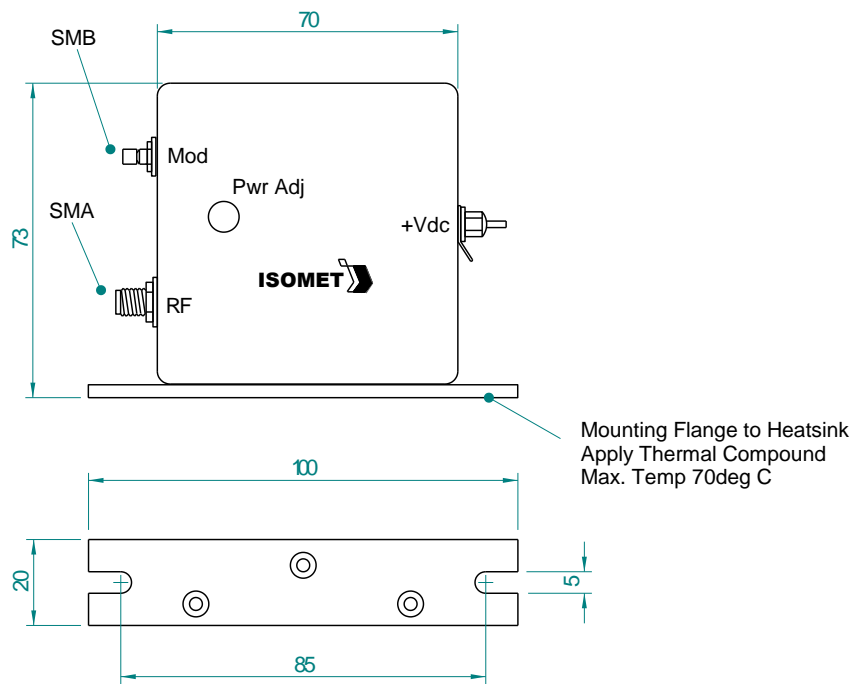

Figure 1: Driver Installation

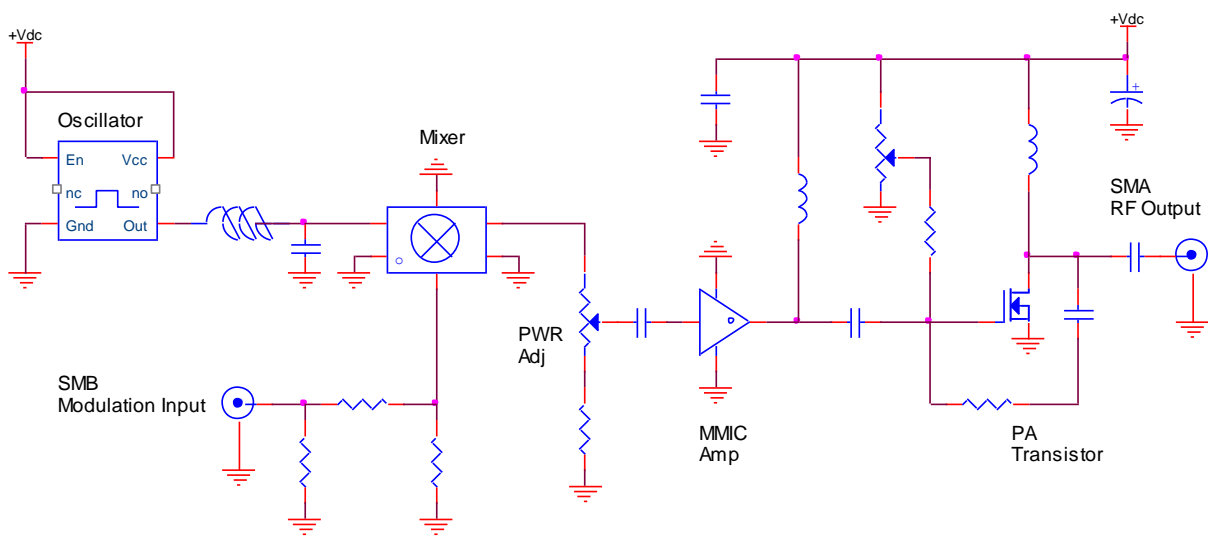
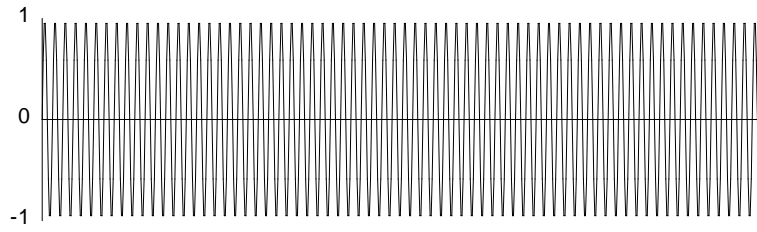
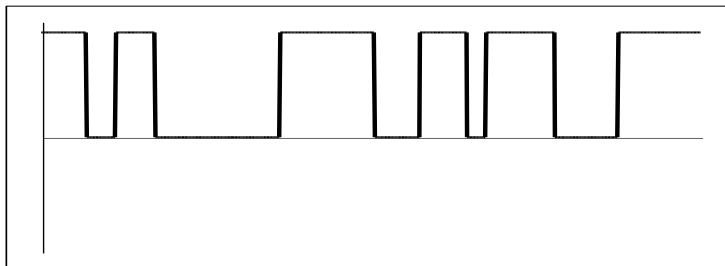

Figure 2: Driver Block Diagram



RF Carrier



Video Input

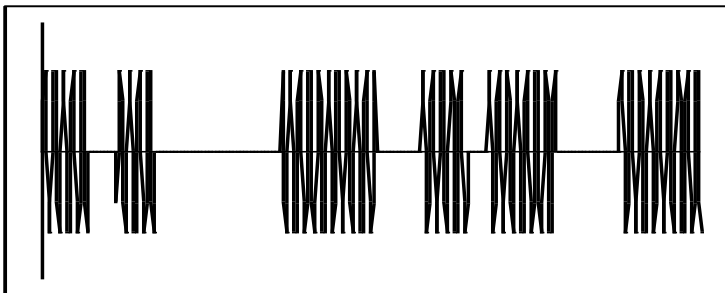

Modulated RF

Figure 3: Typical Digital Modulation Waveforms

Schematic for an AO modulator with 522c digital driver

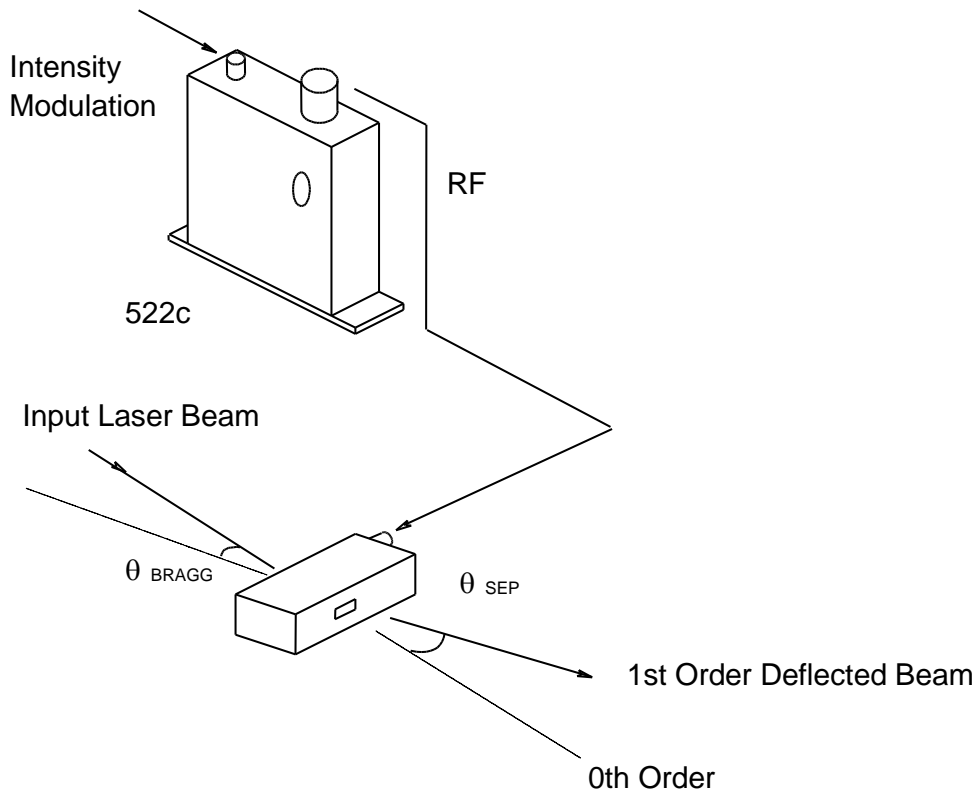

The input Bragg angle, relative to a normal to the optical surface and in the plane of deflection is :

$$\theta_{BRAGG} = \frac{\lambda \cdot f_c}{2 \cdot v}$$

The separation angle between the zeroth order and the first order outputs is :

$$\theta_{SEP} = \frac{\lambda \cdot f_c}{v}$$

Optical rise time for a Gaussian input beam is approximated by :

$$t_r = \frac{0.65 \cdot d}{v}$$

where : λ = wavelength

f_c = centre frequency = 80MHz

v = acoustic velocity of AO interaction material = 4.21mm/usec (TeO₂)
 = 3.63mm/usec (PbMoO₄)
 = 5.96mm/usec (Fused Si)

$d = 1/e^2$ beam diameter

Figure 5: Modulation System