

Feb 17



Acousto-Optic Modulator Driver

**Including: Basic Modulator Alignment
for 1211 series**

Instruction Manual

RFA2110 Series

Models -

RFA2110-x : 110MHz, > 25W output
RFA2110-L-x : 110MHz, > 12W output

Options -x:

- V : 0-5V analog modulation range
- A : analog modulation only. No RF gate
- D : digital modulation only. No RF gate
- R : coolant fittings on rear face

ISOMET CORP, 5263 Port Royal Rd, Springfield, VA 22151, USA.
Tel: (703) 321 8301, Fax: (703) 321 8546, e-mail: isomet@isomet.com
www.ISOMET.com

ISOMET (UK) Ltd, 18 Llantarnam Park, Cwmbran, Torfaen, NP44 3AX, UK.
Tel: +44 1633-872721, Fax: +44 1633 874678, e-mail: isomet@isomet.co.uk



1. GENERAL

The RFA2110 combined Analog Driver and Power Amplifier is a fixed frequency RF power source specifically designed to operate with Isomet acousto-optic devices such as the 1211 or M1062 series. The driver accepts **two** independent digital and analogue modulating signals and provides a double-sideband amplitude modulated RF output to the acousto-optic modulator. A summary of the driver specification is shown in the following table:

<u>Model</u>	<u>Use With</u>	<u>Center Frequency</u>	<u>Output Power</u>
RFA2110	1211-3-985	110MHz	12.0 Watts at 532nm
	M1340-aQ110-5	110MHz	9.0 Watts at 355nm
RFA2110L	M1062-FS110-3	110MHz	10.0 Watts at 355nm

Figure 2 is a functional block diagram of the driver. The center frequency of the driver is determined by the free-running quartz-crystal oscillator at 110MHz. This frequency is accurate to within $\pm 0.003\%$ and its stability is better than $\pm 0.003\%$; the oscillator is not temperature stabilized.

A high-frequency, diode ring modulator is used to amplitude-modulate the RF carrier. The single turn potentiometer provides gain control for adjusting the maximum r-f power at the Driver output.

A solid state switch provides the Digital Modulation or RF Gating function. A TTL high level will gate the RF ON. The MMIC r-f pre-amplifier stage isolates the low level modulation and control circuitry from the power amplifier stage.

The rise and fall times for the amplifier from either modulation input is identical (approx 200nsec).

The video analog input level must not exceed 15 volts

The digital input level must not exceed 7 volts

The RF modulation functions are shown in Figure 3



This amplifier is designed to operate at full rated power into a 50 Ω load with 100% duty cycle.

Water cooling is mandatory. The heatsink temperature must not exceed 70°C.

**SERIOUS DAMAGE TO THE AMPLIFIER MAY RESULT IF THE TEMPERATURE EXCEEDS 70°C.
SERIOUS DAMAGE TO THE AMPLIFIER MAY ALSO RESULT IF THE RF OUTPUT CONNECTOR
IS OPERATED OPEN-CIRCUITED OR SHORT-CIRCUITED.**

A low impedance d-c power supply is required. The operating voltage is +24V or +28Vdc at a current drain of approximately 4 A. The external power source should be regulated to $\pm 2\%$ and the power supply ripple voltage should be less than 200mV for best results.

Higher RF output power is achieved at 28Vdc.

The output power level is set by the power adjust potentiometer (PWR ADJ)

NOTE : Maximum power = fully clockwise

2, CONTROL

Two inputs directly control the RF output; *Gate* and *Modulation*.

The Gate response time (t_{gm} , Fig1) is approximately 200nsec

The RF Modulation response time is < 50 nsec

The relationship between the driver control inputs, the RF waveform and AO response is shown below for analog modulation type.

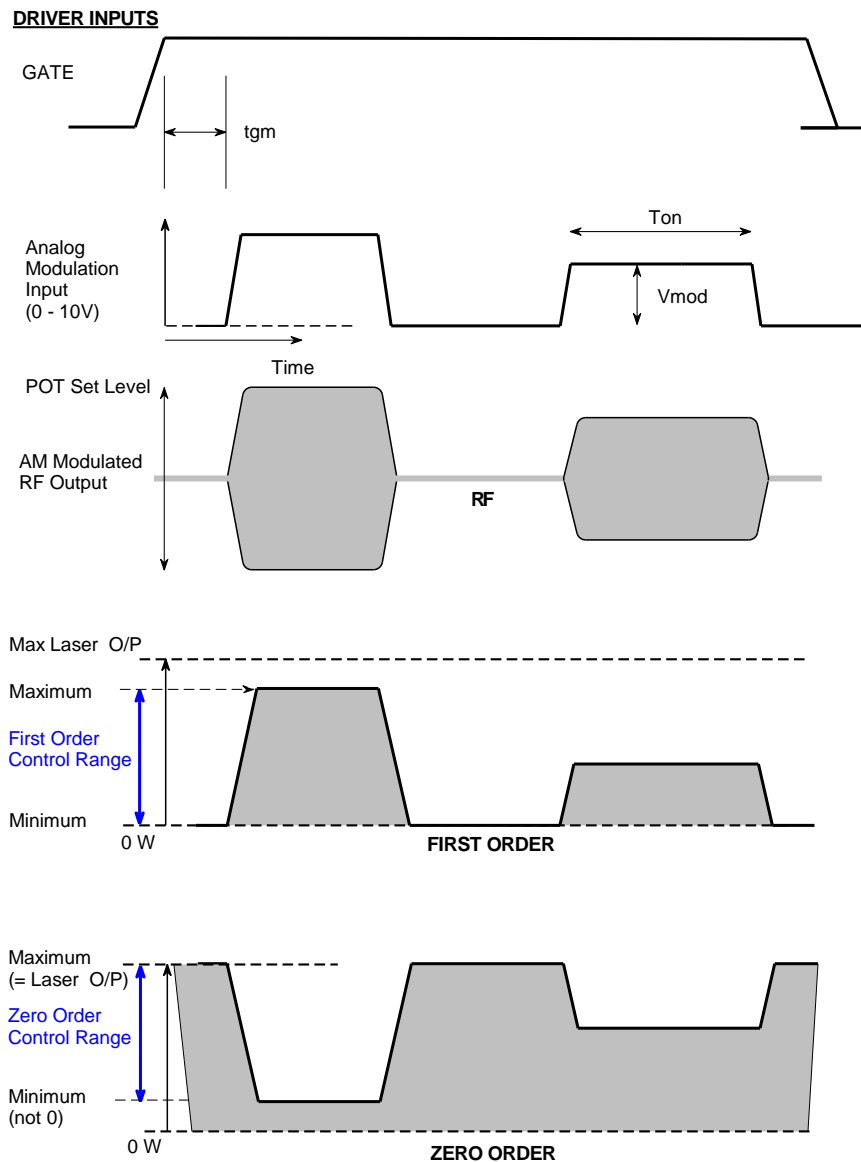

Figure 1: Typical Modulation Waveforms



Gate (active high enables the RF amplifier)

TTL compatible input

Default condition is RF Off.

A high level ($1.7V < V < 5V$) will gate the RF **ON**.

A low level ($0V < V < 0.8V$), or not connected will gate the RF **OFF**.

Analog Modulation (0 - 10V)

Provides high speed proportional amplitude control of the RF output.

Lower limit: an input voltage of less than 0.4V will drive the RF Off.

Upper limit: an input of 10V will result in the maximum RF output,

(For RFA2110D type, modulation control is On:Off and requires a 5V CMOS / TTL compatible input).

The amplitude level is defined by the selected RF power adjustment POT.

RF Power Adjustment (POT set level)

The maximum RF power limit is set using a manual adjust multi-turn potentiometer 'PWR ADJ'.

Maximum RF power = fully clockwise

3 LED INDICATORS

The front panel LEDs serve to indicate a number of possible operating states.

The LEDs [C] and [D] illuminate when the DC power is applied and the Interlocks are valid.

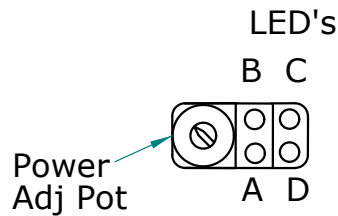

- [A] Shows GREEN when the RF output is live PROVIDED:
 - a) the modulation duty cycle is more than 20% (approx).
 - b) the RF CW power is > 20% (approx) of the driver maximum power
- [B] Not applicable – for future options
- [C] shows RED when the DC power is applied
- [D] shows GREEN when the (thermal) Interlocks are enabled

Caution, the RF output may be live even if these LED's are not illuminated.

LEDs Off

The LEDs [C] and [D] will not illuminate if :

- a) the internal driver thermal interlock switch is open (Over temperature fault)
- b) the AOM thermal interlocks switch is open (Over temperature fault)
- c) the AOM thermal interlock is not connected to the driver interlock input
- d) the DC supply is off.

The thermal interlocks will reset once the AO device and / or RF driver are cooled below the switching temperature.

- The driver thermal switch over temperature is 50deg C
- The AOM thermal switch over temperature is 35deg C

The hysteresis of the thermal switches is 7-10deg C.

Once in a fault state the coolant temperature may need to be reduced to reset the thermal switches.

4. INSTALLATION AND ADJUSTMENT

- 4.1 Connect cooling water to the RFA2110
Connect cooling water to the AO device.

Due to the high RF power dissipated in the AO modulator, it is paramount that the device is operated only when water cooling is circulating.

For optimum AO performance ensure the flow rate is not less than 0.5 litres/minute at < 25 degC

- 4.2 With no d-c power applied, connect the + 24V (or +28V) DC in to the center terminal of the feed-thru terminal. DO NOT APPLY POWER.
- 4.3 Connect the RF output BNC jack to the acousto-optic modulator (or a 50Ω RF load, if it is desired to measure the modulator RF output power).
- 4.4 Connect the Interlock of the acousto-optic modulator (SMA, SMC or mini 3pin connector) to the enable inputs on the 9-pin D-type connector of the RFA. Connect pin 4 of 'D' to the centre pin of the SMA/SMC and pin 5 of 'D' to the outer ground of the SMA.

The interlock connection becomes open circuit, disabling the RF output if the temperature of the modulator exceeds 35°C or the internal driver temperature exceeds 70°C. LED indicator illuminates when the Interlocks are closed and the RF is enabled (see Section 3). In addition, a CMOS 'interlock valid' signal output is provided on pin 1 of the D-type connector for remote monitoring purposes.

- 4.5 Adjustment of the RF output power is best done with amplifier connected to the acousto-optic modulator. The Amplifier maximum output power is factory preset to approx 9W.

The optimum RF power level required for the modulator to produce maximum first order intensity will be different at various laser wavelengths. Applying RF power in excess of this optimum level will cause a decrease in first order intensity (a false indication of insufficient RF power) and makes accurate Bragg alignment difficult. It is therefore recommended that initial alignment be performed at a low RF power level.

- 4.6 Locate the PWR ADJ access on the driver end plate.



- 4.7 With an insulated alignment tool or screwdriver rotate the PWR ADJ potentiometer fully anti-clockwise (CCW) , then clockwise (CW) approx 1/4 turn.
- 4.8 Apply DC to the amplifier.
- 4.9 Apply a 10.0V constant signal to the Analog modulation input on the D-type connector. Connect pin 8 of 'D' to the signal and pin 9 of 'D' to the signal return.
- 4.10 Apply a constant TTL high level to the digital Gate input on the D-type connector. Connect pin 6 of the 'D' to the signal and pin 7 of the 'D' to the signal return.

Input the laser beam toward the centre of either aperture of the AOM. Ensure the polarization is vertical with respect to the base and the beam height does not exceed the active aperture height of the AOM.

Start with the laser beam normal to the input optical face of the AOM and very slowly rotate the AOM (either direction). See Figure 4 below for one possible configuration.

- 4.11 Observe the diffracted first-order output from the acousto-optic modulator and the undeflected zeroth order beam. Adjust the Bragg angle (rotate the modulator) to maximise first order beam intensity.
- 4.12 After Bragg angle has been optimized, slowly increase the RF power (rotate PWR ADJ CW) until maximum first order intensity is obtained.
- 4.13 The driver is now ready for use for modulation using both the digital and the analog inputs.

5. MAINTENANCE

5.1 Cleaning

It is of utmost importance that the optical apertures of the deflector optical head be kept clean and free of contamination. When the device is not in use, the apertures may be protected by a covering of masking tape. When in use, frequently clean the apertures with a pressurized jet of filtered, dry air.

It will probably be necessary in time to wipe the coated window surfaces of atmospherically deposited films. Although the coatings are hard and durable, care must be taken to avoid gouging of the surface and leaving residues. It is suggested that the coatings be wiped with a soft ball of brushed (short fibres removed) cotton, slightly moistened with clean alcohol. Before the alcohol has had time to dry on the surface, wipe again with dry cotton in a smooth, continuous stroke. Examine the surface for residue and, if necessary, repeat the cleaning.

5.2 Troubleshooting

No troubleshooting procedures are proposed other than a check of alignment and operating procedure. If difficulties arise, take note of the symptoms and contact the manufacturer.

5.3 Repairs

In the event of deflector malfunction, discontinue operation and immediately contact the manufacturer or his representative. Due to the high sensitive of tuning procedures and the possible damage which may result, no user repairs are allowed. Evidence that an attempt has been made to open the optical head will void the manufacturer's warranty.

Connection Summary

1.0 'D' Type Control Connection

<u>Signal</u>	<u>Type</u>	<u>Pin out connection</u>
Digital Modulation / GATE TTL high (>1.7V) = ON TTL low (<0.8V) or no connection = Off	Input	Signal pin 6 Return pin 7
Analogue Modulation 0.0V(off) to 10.0V(on)	Input	Signal pin 8 Return pin 9
Interlock (connect to AO modulator 'INT')	Input	Signal pin 4 Return pin 5
'Interlock Valid' monitor (CMOS compatible ~15V = OK)	Output	Signal pin 1 Return pin 2

Minimum Connections shown below:
(Note: AOM thermal interlock connector type is model dependent)

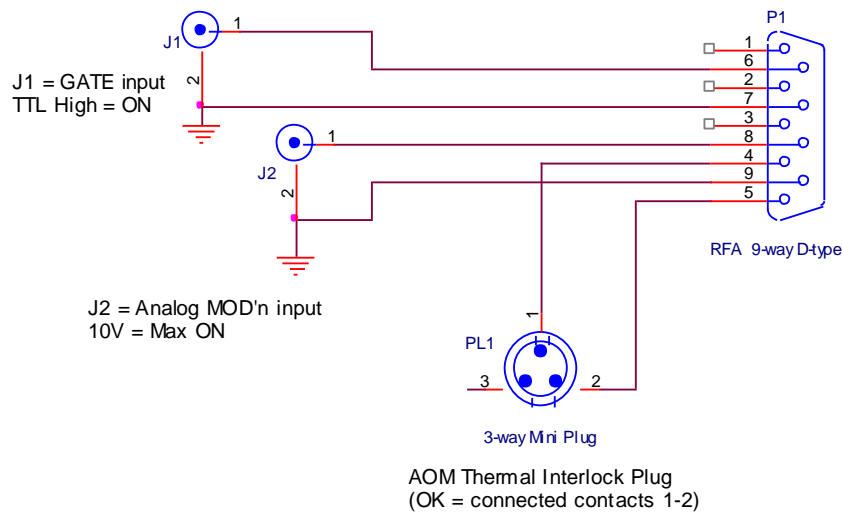

Notes:

Both Digital GATE and Analog Modulation signals need to be applied.
The interlock signal must be connected. Contacts closed for normal operation.

2.0 Mounting Holes

4 x M5

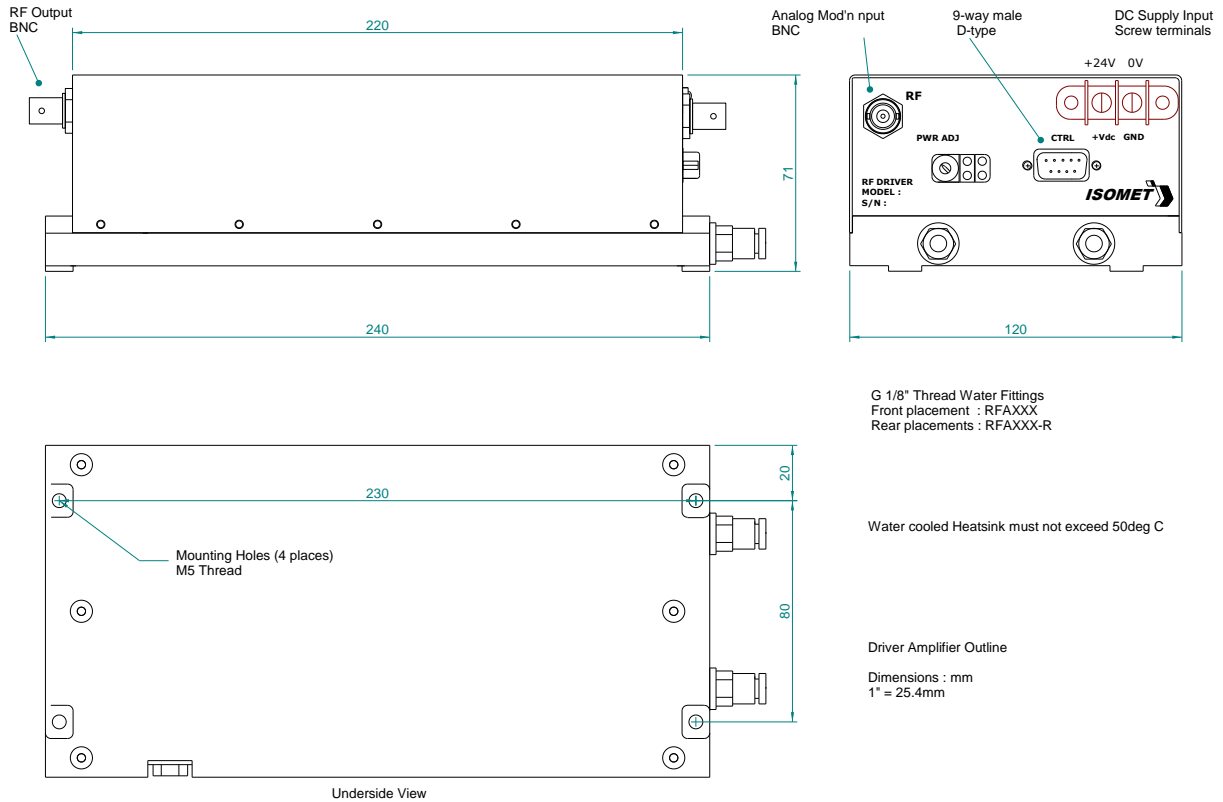

Figure 1: Driver Installation

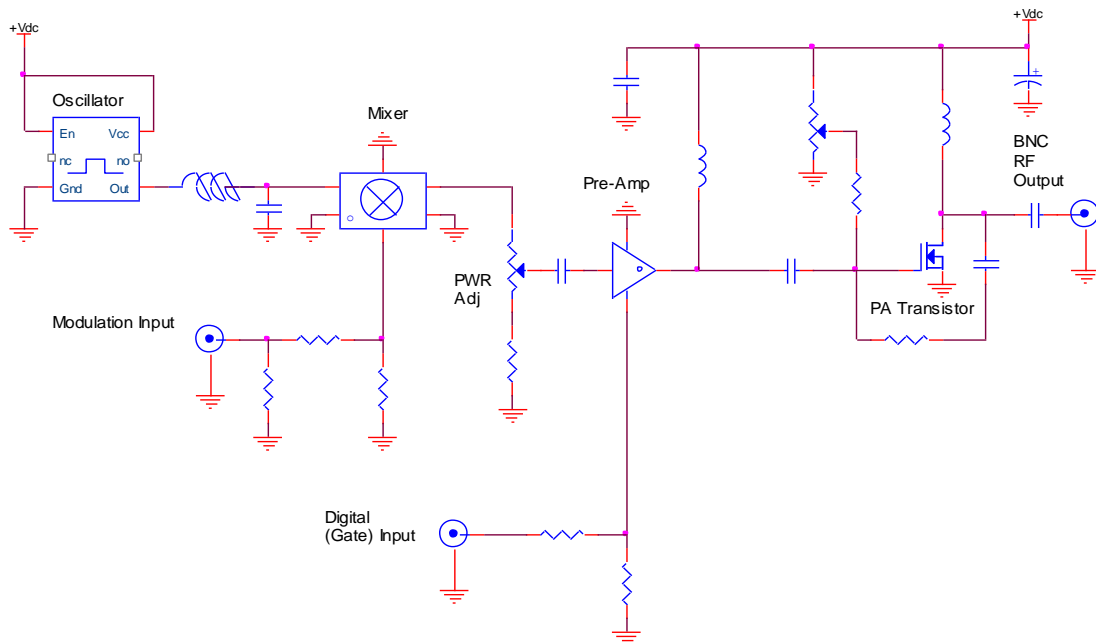
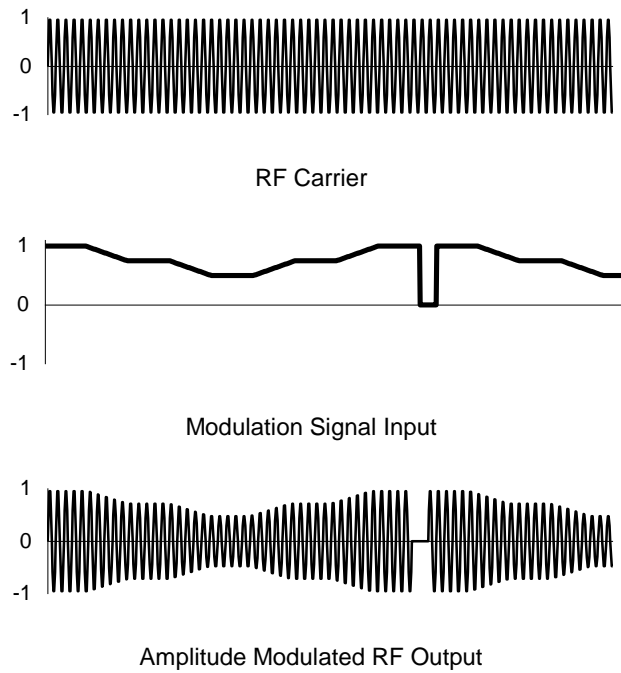

Figure 2: Driver Block Diagram



Typical analog modulation RF waveforms are shown above.

For the RFA2110 and similar drivers, the modulation input is a combination of analog and digital control as illustrated below.

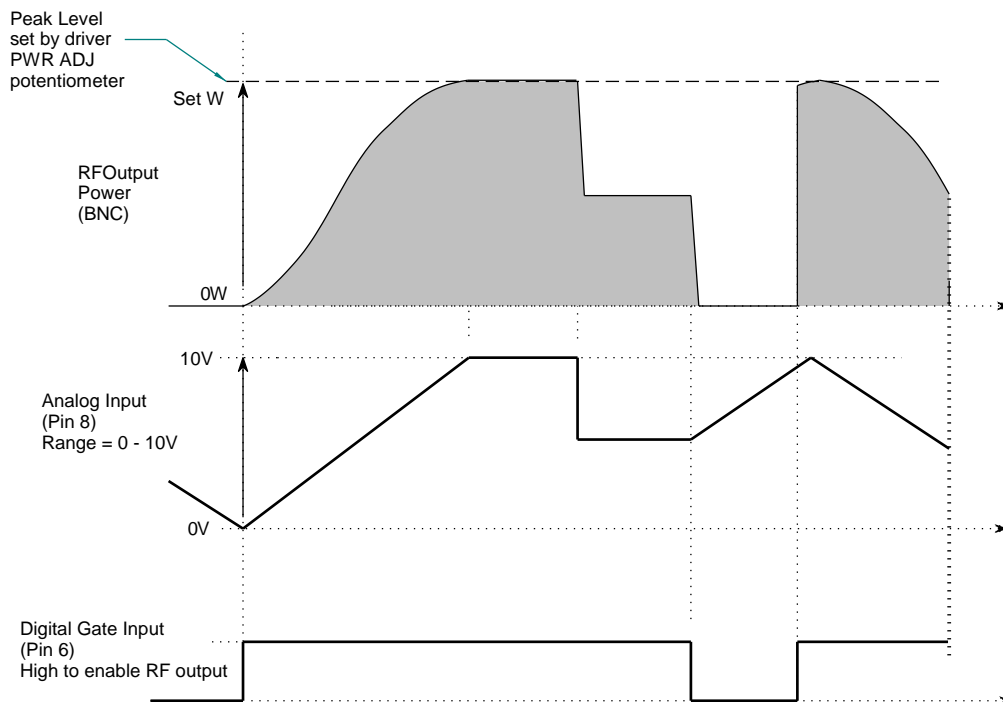

Figure 3: Typical Analog Modulation RF Waveforms

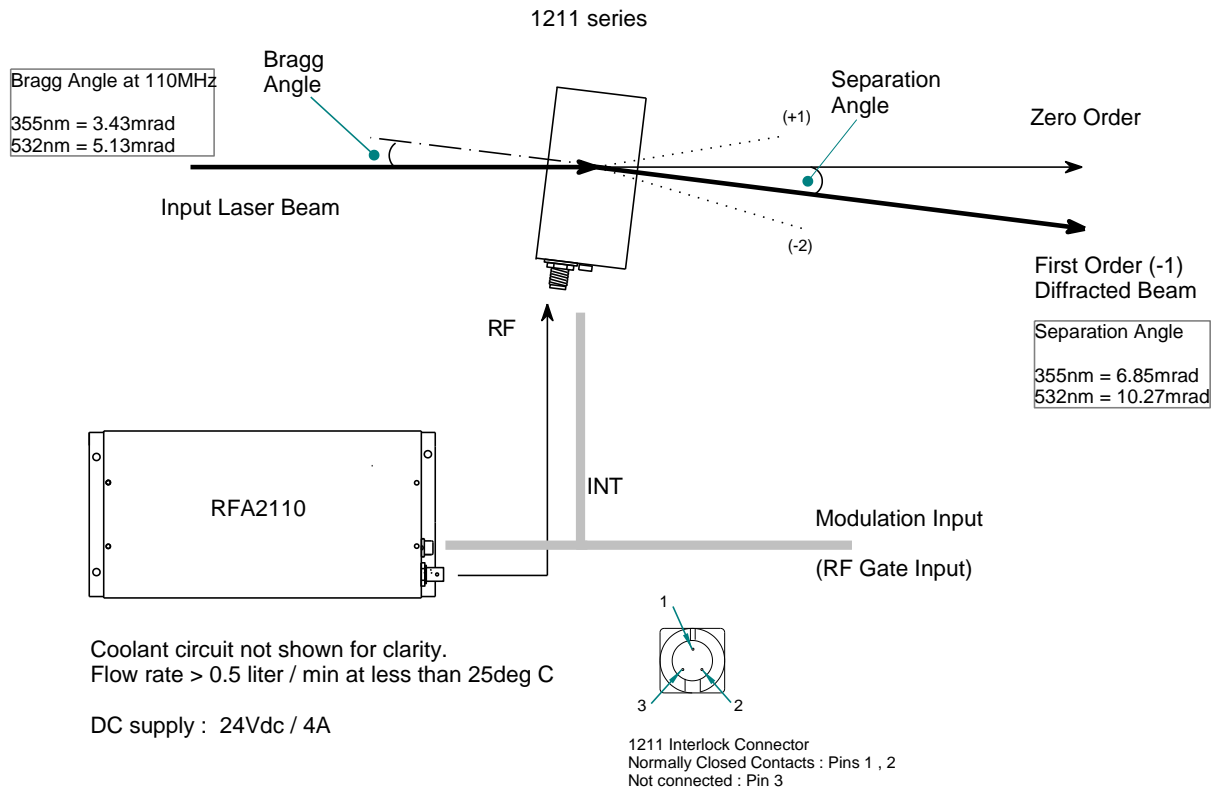
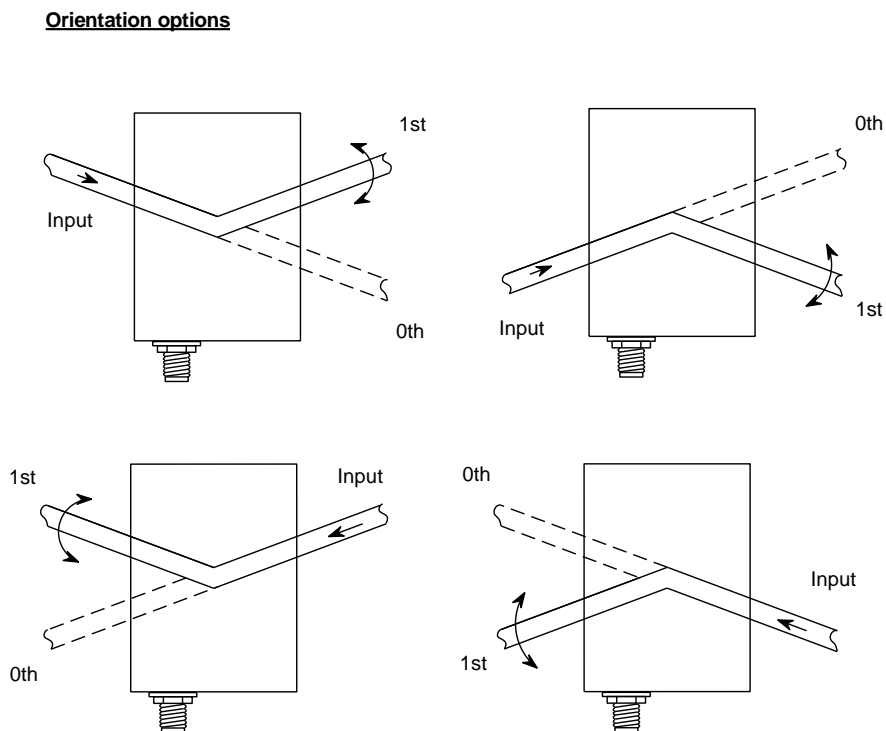
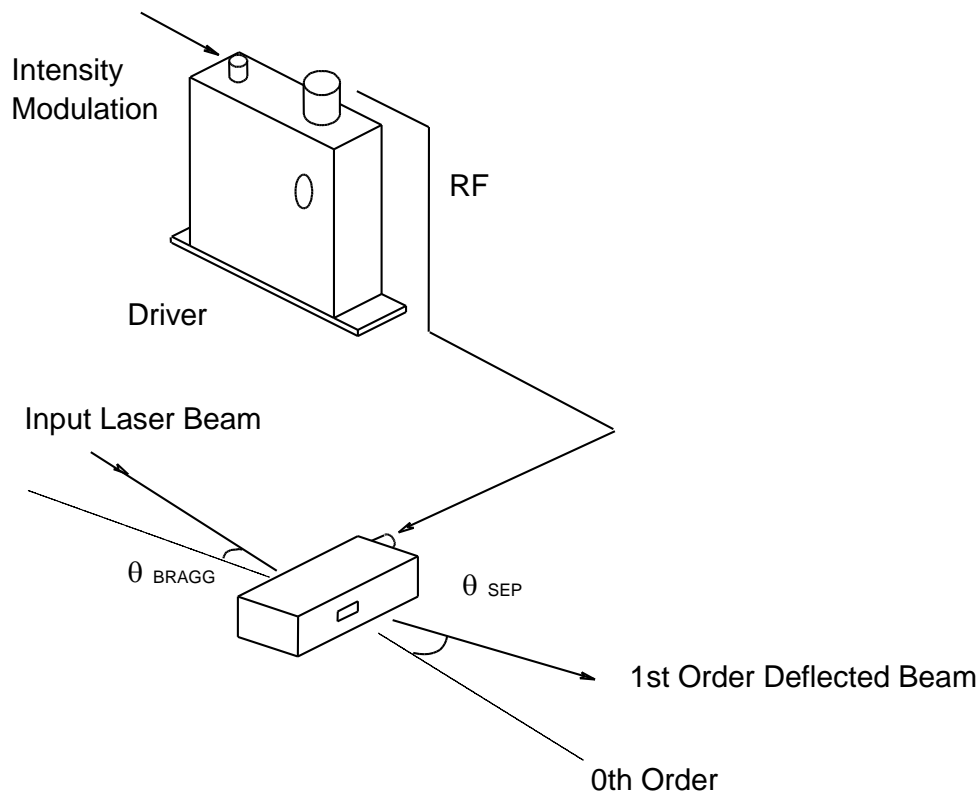

Figure 4: Typical Connection Configuration



Basic AO Modulator Parameters



The input Bragg angle, relative to a normal to the optical surface and in the plane of deflection is:

$$\theta_{\text{BRAGG}} = \frac{\lambda \cdot f_c}{2 \cdot v}$$

The separation angle between the Zeroth order and the First order is:

$$\theta_{\text{SEP}} = \frac{\lambda \cdot f_c}{v}$$

Optical rise time for a Gaussian input beam is approximately:

$$t_r = \frac{0.65 \cdot d}{v}$$

where:

λ = wavelength

f_c = centre frequency = 110MHz

v = acoustic velocity of interaction material

$d = 1/e^2$ beam diameter

= 5.7mm/usec (Quartz)

= 5.96mm/usec (Fused Silica)

Figure 5. Modulation System