



Acousto-Optic Deflector Driver
Including: Basic Deflector Alignment

Instruction Manual
RFA3110-4(BS) series rev 4

Models -

RFA3110-4 : 10V Tuning Input, 10V Analog Modulation Input

RFA3110-4-CC : conduction cooled

ISOMET CORP, 5263 Port Royal Rd, Springfield, VA 22151, USA.
Tel: (703) 321 8301, Fax: (703) 321 8546, e-mail: isomet@isomet.com
www.ISOMET.com
ISOMET (UK) Ltd, 18 Llantarnam Park, Cwmbarn, Torfaen, NP44 3AX, UK.
Tel: +44 1633-872721, Fax: +44 1633 874678, e-mail: isomet@isomet.co.uk



1. GENERAL

The RFA3110-4 Deflector Driver, figure 1, is a modular, swept-frequency RF power source specifically designed to operate with acousto-optic deflectors. The driver accepts a tuning voltage, typically between approximately +0 volts and +10 volts and provides an RF output to the acousto-optic deflector at the tuned frequency. The driver also accepts a modulating signal at baseband video frequency and provides a double-sideband amplitude modulated RF output to the acousto-optic deflector. A summary of the driver specification is shown in the following table:

Model	Tuning Range	Modulation	Output Power
RFA3110-4	85-135MHz (Nominal)**	Analog	2Watt per channel

Figure 2 is a block diagram of the Driver. The output frequency of the driver is controlled by a hybridized varactor oscillator circuit. The capacitance of the internal varactor is a function of the applied tuning voltage. The output frequency is proportional to the input tuning voltage with a scale factor of approximately 5.0 MHz/volt. A table of output frequency versus input tuning voltage is supplied with each driver; a typical voltage vs. frequency curve is shown in figure 4. The frequency linearity is typically $\pm 1.5\%$, and frequency stability is typically $\pm 0.25\%$.

The oscillator output is connected to a matched RF splitter. This provides signal to a diode ring RF modulator and the frequency monitor output. The frequency monitor output provides a low level (approx. 300mVpp) output signal at the tuned operating frequency. This can be used for measurement or feedback purposes.

*** A multi-turn variable potentiometer situated to the right of the front panel LED's allows adjustment of start frequency. This is the frequency output at 0V tuning voltage input.
For optimum scan flatness, the operating frequency range may be need to be centered +/- 5MHz from the nominal 110MHz.
The limits of this adjustment cover the full tuning range. This allows the driver output frequency to be set at any fixed point across the frequency range.*

A high-frequency, diode ring mixer is used to amplitude-modulate the RF carrier. The baseband video input, from an external 50Ω drive source, is the modulating input to the diode ring mixer. For the RFA3110-4, a video input swing of 10 volt peak to peak positive with respect to ground) will result in 100% depth of modulation.

The amplitude-modulated RF is applied to a splitter and amplified to a preset level in the four power hybrid stages. The output hybrid amplifiers are designed to operate at full rated power into a 50Ω load with 100% duty cycle. The output power level is set by the power adjust potentiometer.

The phase delay on outputs J2, J3 and J4 are defined by an internal delay lines. The delay value is specific to the design of the beam steered deflector.

Figure 3 illustrates the principal waveforms of the RFA3110-4 Driver.

Connect cooling water at a flow rate greater than 0.25 litres/minute at less than 25 deg.C

The mounting face temperature must not exceed 70°C.

Serious damage to the amplifier may also result if the RF output connector is operated open-circuited or short-circuited.

A low impedance source of d-c power is required for operation of the Driver. The required voltage is +24Vdc or +28Vdc at a current drain of < 3A. The external power source should be regulated to ± 1.5% and the power supply ripple voltage should be less than 200mV for best results.

Front panel indicators and adjustments

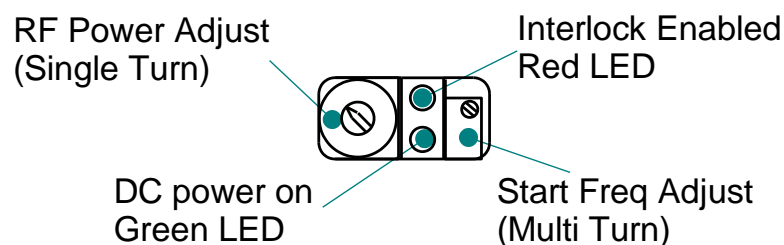



2. SPECIFICATIONS

Oscillator Type:	Varactor-tuned thin film hybrid
Amplifier Type:	Broadband Class A
Output RF Power:	> 1.9 Watt / output (24Vdc)
Output Impedance:	50Ω nominal
Load VSWR:	< 2.5:1 for best results
Output RF Power Variation vs. Frequency	< 1 dB
Spurious Outputs:	Harmonics > 20dB below fundamental
Tuning Range:	80 to 140 MHz Maximum 85 to 135MHz Typical (or as specified)
Tuning Voltage:	0 to 10V typical
Tuning Linearity:	<1.5% over specified tuning range

**DO NOT APPLY NEGATIVE TUNING VOLTAGE
DO NOT EXCEED + 20V INPUT
DAMAGE MAY RESULT**

Tuning Voltage Impedance:	Drive from low impedance source, 50Ω or less
Tuning Slew Rate	> 10 MHz/μs
Residual FM:	< 10 KHz peak-to-peak
Frequency Stability:	±0.25%
Mod Input Voltage,	0-10V for 100% modulation depth
Input Impedance:	50Ω source
RF ON-OFF Ratio:	> 33 dB
DC Power Input:	+24Vdc or +28Vdc at <3A regulated to ± 1.5%
Temperature Range:	0°C to 60°C ambient, temperature at mounting face must not exceed 70°C Water cooled.
Mounting Orientation:	Any

3. THEORY OF OPERATION

Figure 5 illustrates the key operating parameters. Further explanation is given in the accompanying application notes 'Acousto Optic Deflectors'.



4. INSTALLATION AND ADJUSTMENT (Also see Appendix A page 14)

- a. Connect cooling water at a flow rate greater than 0.25 litres/minute at less than 25 deg.C

- b. With no d-c power applied, connect the + 28V DC to the center terminal of the feed-thru terminal 1. DO NOT APPLY POWER. (+24Vdc may be used, with reduced maximum RF power).

- c. Align the deflector head to insure that the incident light beam is centred in the active aperture of the deflector.

- d. Connect the four SMA connectors of the deflector to the RF outputs of the RFA3110-4 beam steered driver. Ensure the coax cables are of equal length. The driver RF outputs must be connected to the AO deflector in an order that depends on the Bragg orientation. Figure 4 illustrates the options. The order of connection is important. The deflector will not be damaged if the order is incorrect but the amplifier outputs must be terminated. If the RF cable connections are incorrect, the deflection efficiency will vary considerably as the deflector frequency is changed.

If required apply a 12V CMOS compatible or open drain connection to the Digital Gate input

- Connect the tuning signal (12v maximum) to pin 7
- Connect the signal return (0V) to pin 2

This input is optional and may be left NC (Not Connected).

A closed contact on this input will disable the RF Output. Switching response time 10msec

Connect the external Interlock of the acousto-optic modulator (if fitted) to the enable inputs on the 9-pin D-type connector. If no interlock is fitted then these inputs MUST be connected together.

- Connect pin 9 to the floating contact 1 of the interlock switch.
- Connect pin 4 to floating contact 2 of the interlock switch. (Grounded at driver)

- e. Connect the amplitude control source to the the D-type connector.

- Connect the modulation signal (0,0 - 10.0V) to pin 8
- Connect the signal return (0V) to pin 3

To begin, apply a constant voltage of 10.0V.

- f. Connect the tuning voltage source to the the D-type connector.

- Connect the tuning signal (0,0 -10.0V) to pin1
- Connect the signal return (0V) to pin 6



To begin, apply a constant voltage of 5V equivalent to the centre frequency of 110MHz or 105MHz. The output frequency can be measured by connecting a frequency counter to the 'Fmon' output BNC connector on the front panel.

g. Start by adjusting the Power adjust potentiometer on the RFA3110-4 to a fully anti-clockwise direction, (Minimum output). The RF power increases with clockwise rotation of the pot.

h. Tune the input frequency source to the mid-frequency point of the AO deflector bandwidth (e.g. 105-110MHz for the D1086 or D1135 -T110L).

i. Apply approximately half the required RF power (say 1.4W / output) at the centre frequency. For the Isomet RFA3110-4BS this is achieved by adjusting the pot 1/3 to 1/2 clockwise from the fully anti-clockwise position. Turn on DC power.

Rotate the deflector slightly until deflection of the light beam occurs. The deflection will occur in the horizontal plane. Select the strongest diffracted spot and monitor the light intensity by using either a photo detector or a light power meter. Re-adjust the Bragg angle for maximum deflected light intensity. Fine tuning of the incident light beam position may be necessary for optimum results.

j. Adjust RF power level carefully for the desired efficiency at the minimum RF power necessary. Do NOT exceed the RF power level at which maximum efficiency is achieved (P_{sat}). Over driving the AO deflector will reduce efficiency and may result in serious damage to the AO crystal.

k. To equalise deflection efficiency at the extremes of the scan, alternate between the minimum and maximum desired frequencies and adjust Bragg angle to give the same efficiency for both. (Note: the photo detector or light power meter will require repositioning for the two angles.) Sweeping the freq' input should result in a continuous deflected line output. If significant peaks and troughs are noted across the sweep, it is probable that the phase delayed outputs of the RFA3110-4BS are connected to the incorrect inputs of the AO deflector. (see Fig 4)

m. The lead lengths between the four outputs of the RFA3110-4 and the beam steered deflector should be equal unless otherwise instructed. Unequal lengths of more than a 1cm would introduce a phase error. Within limits, small changes in the relative lead lengths can be used to fine tune the deflector sweep response, although this is not usually required. The Bragg angle would need re-adjustment.



5. THERMAL EFFECTS

We must consider the thermal effects of this device - both due to optical and acoustic absorption. The majority of heat is generated by RF drive power. As the temperature of the material increases beyond the recommended level, undesired refractive index changes will occur in the material. This results in beam distortion. Ultimately, the crystal will crack due to thermal stresses, if excessive RF power is applied. (>10W for a typical cooled NIR AO deflector).

6. MAINTENANCE

6.1 Cleaning

It is of utmost importance that the optical apertures of the deflector optical head be kept clean and free of contamination. When the device is not in use, the apertures may be protected by a covering of masking tape. When in use, frequently clean the apertures with a pressurized jet of filtered, dry air.

It will probably be necessary in time to wipe the coated window surfaces of atmospherically deposited films. Although the coatings are hard and durable, care must be taken to avoid gouging of the surface and residue of the cleaning solution. It is suggested that the coatings be wiped with a soft ball of brushed (short fibres removed) cotton, slightly moistened with clean alcohol. Before the alcohol has had time to dry on the surface, wipe again with dry cotton in a smooth, continuous stroke. Examine the surface for residue and, if necessary, repeat the cleaning.

6.2 Troubleshooting

No troubleshooting procedures are proposed other than a check of alignment and operating procedure. If difficulties arise, take note of the symptoms and contact the manufacturer.

6.3 Repairs

In the event of deflector malfunction, discontinue operation and immediately contact the manufacturer or his representative. Due to the high sensitive of tuning procedures and the possible damage, which may result, no user repairs are allowed. Evidence that an attempt has been made to open the optical head will void the manufacturer's warranty.

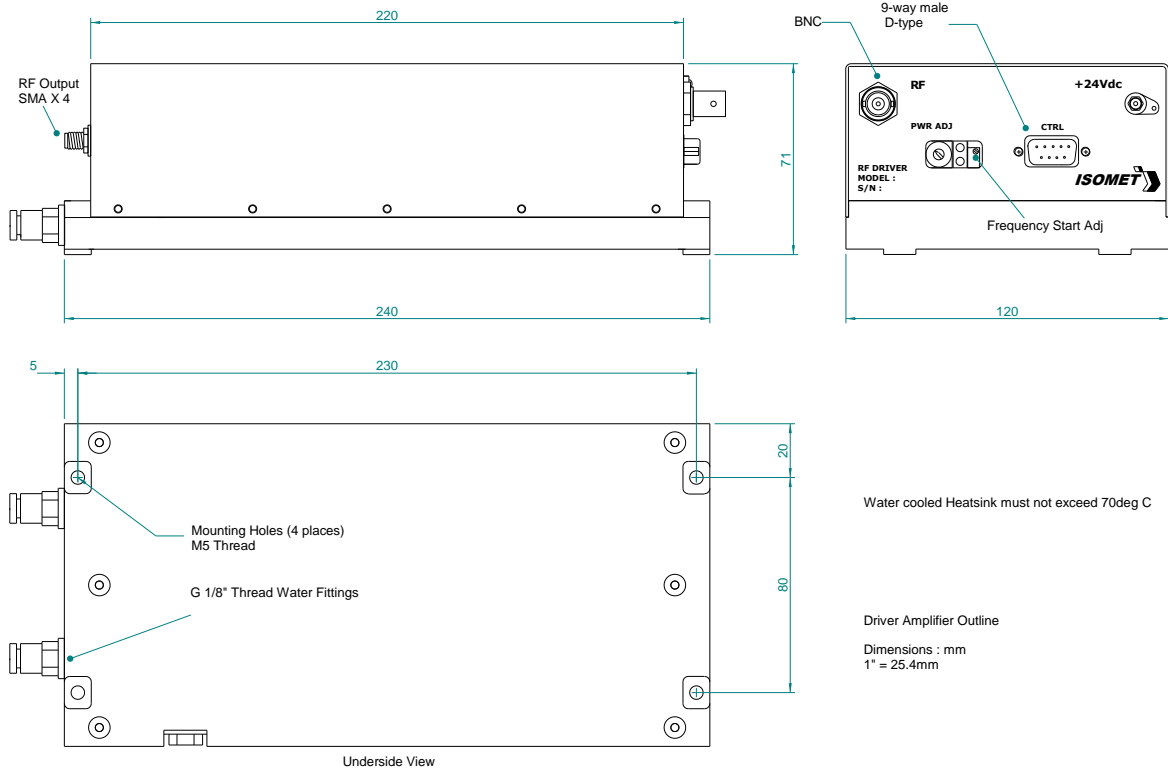

Control signals -	:	9 pin 'D' type
Tuning Voltage (0 -10V)	:	+sig pn1, -rtn pn6
Amplitude Control (0 – 10V)	:	+sig pn8, -rtn pn3
Enable/Interlock Control (Low = On)	:	+sig pn9, -rtn pn4
Digital Gate Input (NC or High = On)	:	+sig pn7, -sig pn2

DC supply connection for drivers fitted with solder feed through

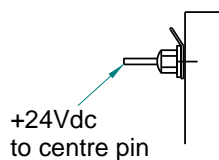

Threaded case stud = 0V connection

Figure 1, RFA3110-4 driver

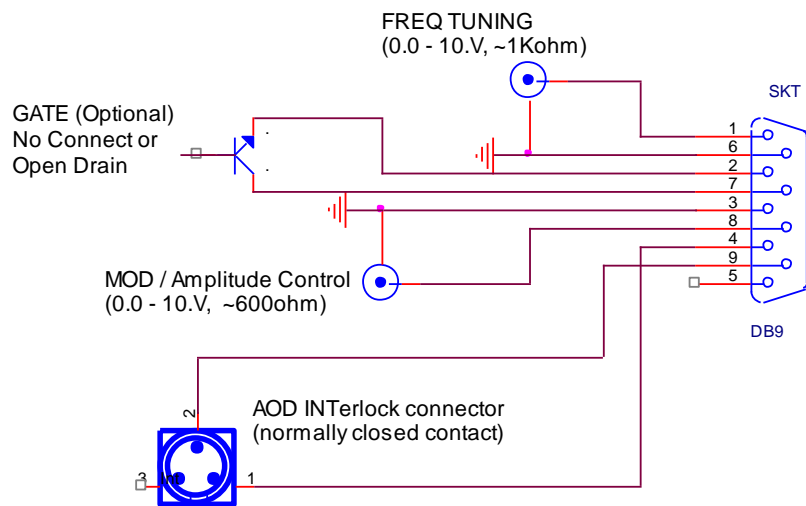
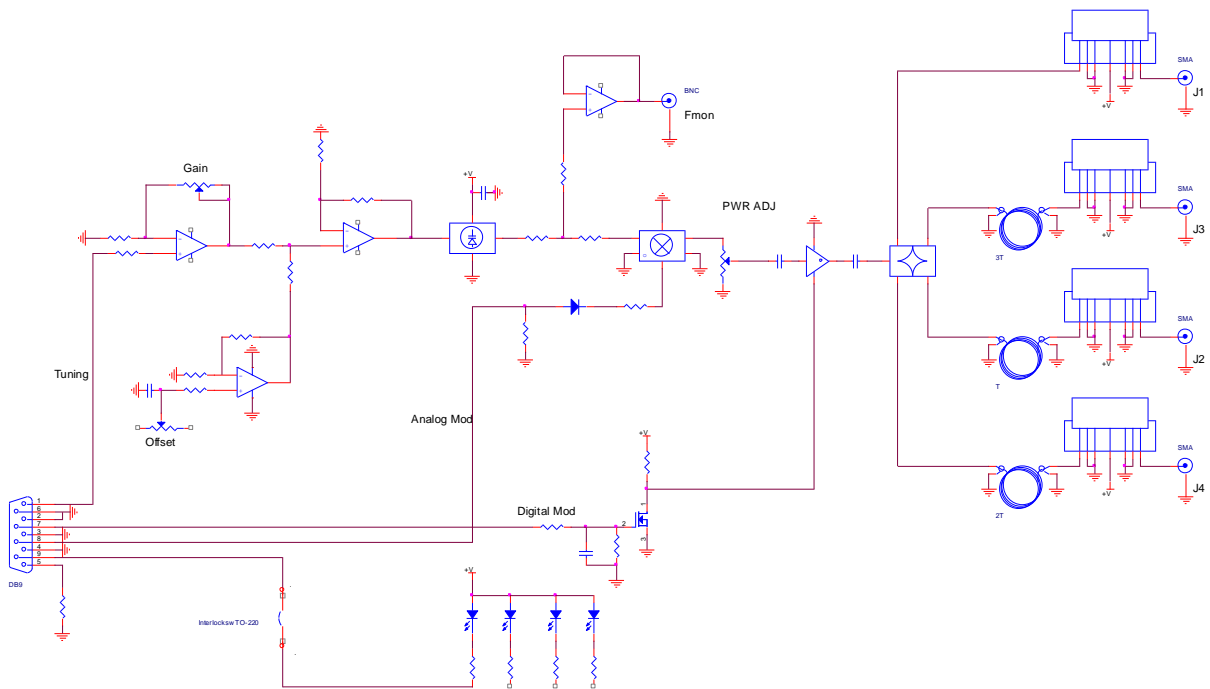
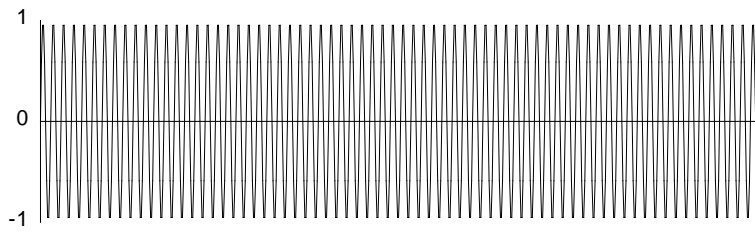
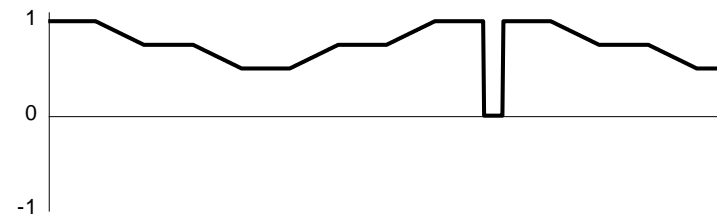

Figure 2, Driver Block Diagram



RF Carrier (FRQ input)



Video Input

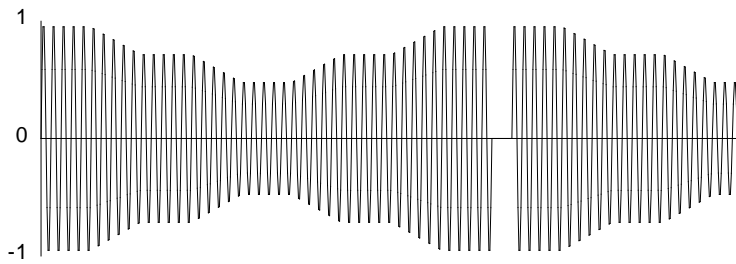

Modulated RF

Figure 3, Typical Amplitude Modulation Waveforms

Connection options for D1086/D1135-T110 Beam Steered AO Deflector with RFA3110-4BS Driver

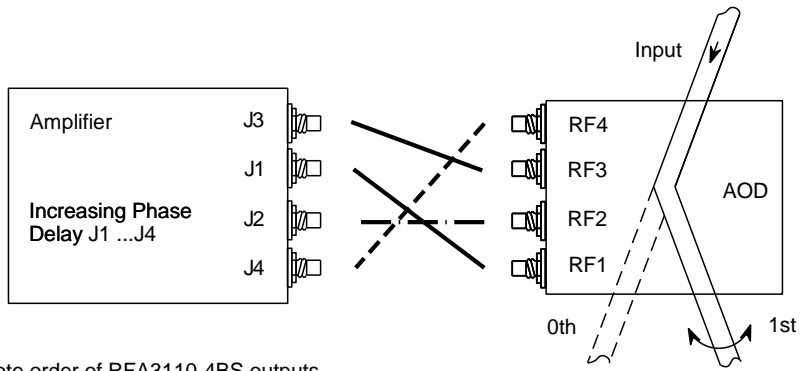

Note order of RFA3110-4BS outputs
i.e. J3,J1,J2,J4

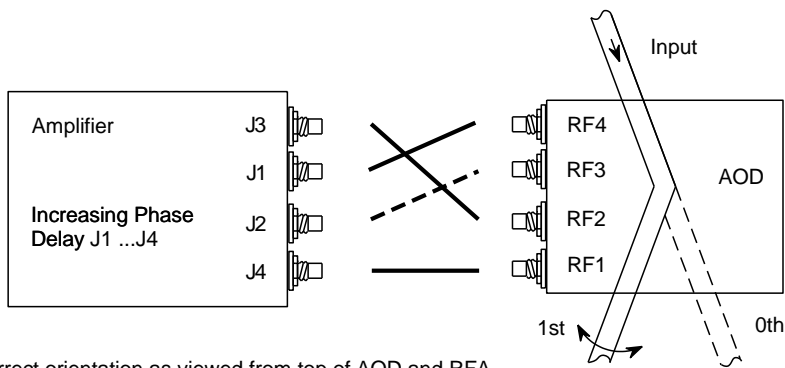

Correct orientation as viewed from top of AOD and RFA
(Connector identification may differ)

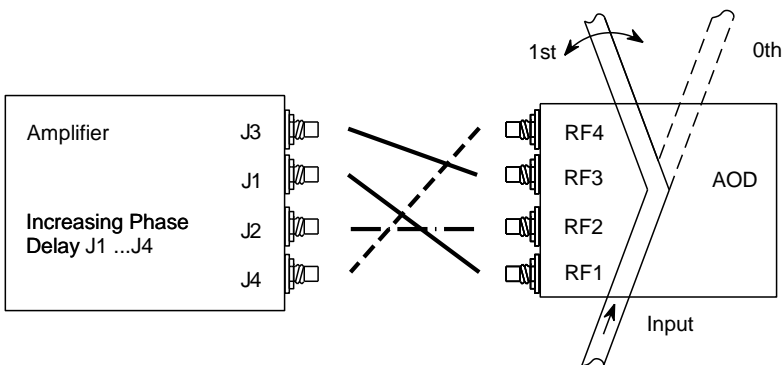
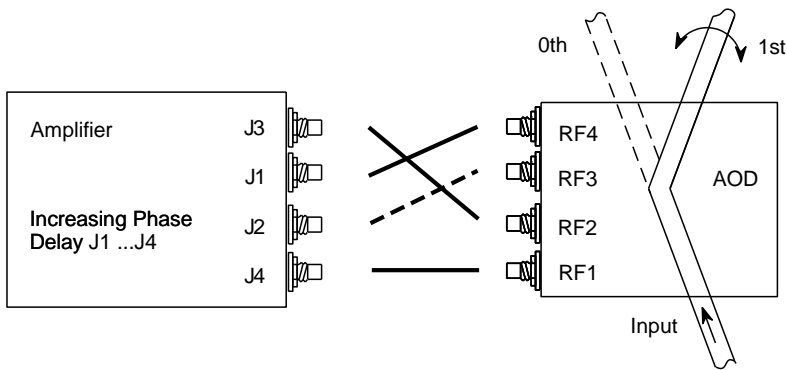
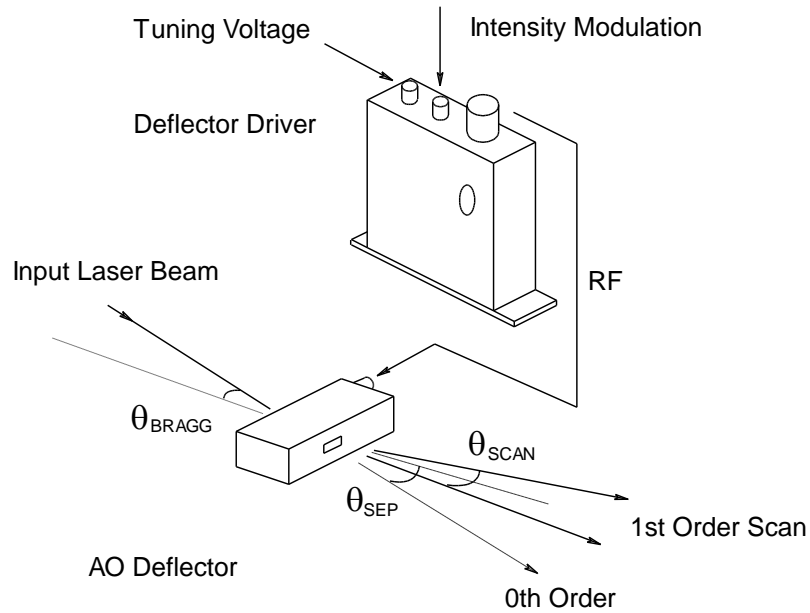

Figure 4

Schematic of a single electrode acousto optic deflector and tunable driver



The input bragg angle, relative to a normal to the optical surface and in the plane of deflection is given by:

$$\theta_{BRAGG} = \frac{\lambda \cdot fc}{2 \cdot v}$$

The separation angle between the zeroth order and mid scan point of the first order is given by:

$$\theta_{SEP} = \frac{\lambda \cdot fc}{v}$$

The first order scan angle is given by:

$$\theta_{SCAN} = \frac{\lambda \cdot \delta f}{v}$$

The access time or time aperture is given by:

$$T_{acc} = d/v$$

- where :
- λ = wavelength
 - δf = scan frequency bandwidth
 - fc = centre frequency
 - v = acoustic velocity of the crystal material (TeO2 = 4.2mm/usec)
 - d = beam diameter

Figure 5, Deflector Parameters

Typical orientation

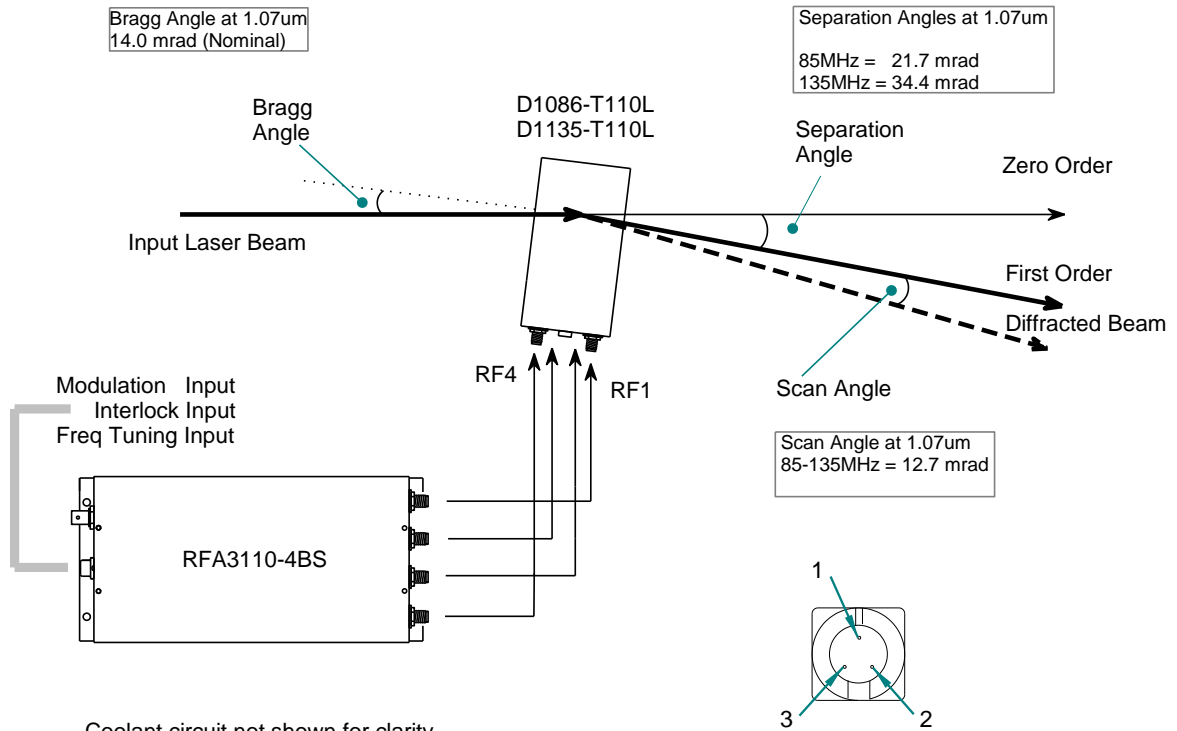

Coolant circuit not shown for clarity.
Flow rate > 1 liter / min at less than 20deg C

DC supply : 24Vdc / 2A

AOM/AOD Interlock Connector
Normally Closed Contacts : Pins 1 , 2
Not connected : Pin 3

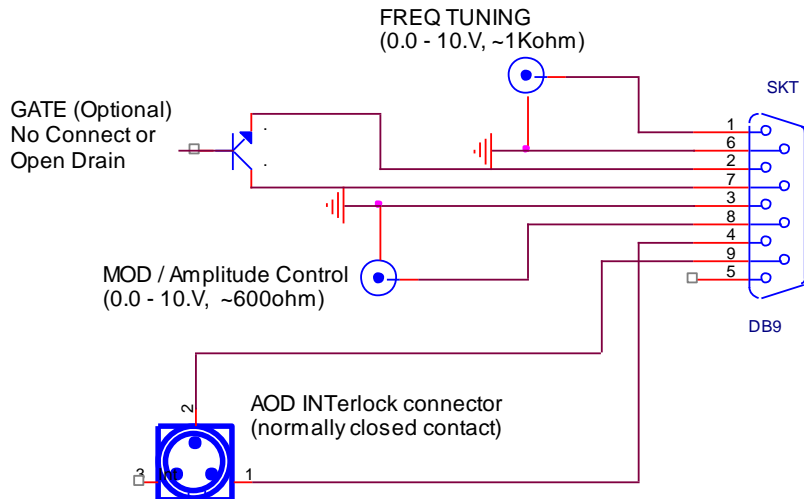

Appendix A

D1086/D1135 Bragg alignment

Power adjustment pot on the RFA3110-4 is by a single turn. An "out of box" RF driver will have an RF power set at 1.6W per output. This is typically less than the optimum RF driver level. If in doubt, begin at step 1

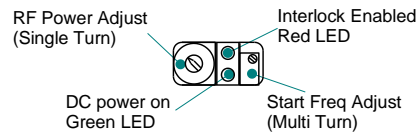

The following set-up is to achieve the full 50MHz sweep (13mrad scan at 1.1 μ m) centered at 110MHz. In this case, the start frequency adjustment on the RFA3110-4 driver should be set to give 85MHz for a 0V tuning input ($V_t = 0V$). The driver tuning characteristic is approx 5MHz/Volt.

(For a mid scan set-up at 105MHz, the start frequency adjustment should be set to give 80MHz for a 0V tuning input ($V_t = 0V$). Values for 105MHz centre are in [] below).

The initial steps set the best peak RF power level for all frequencies and are best made at a point 10% (approx) above the centre frequency.

- 1: Adjust the RF power fully anti-clockwise and then clockwise $\frac{1}{2}$ turn
- 2: Apply a constant and maximum modulation input of 10V.
- 3: Apply a fixed tuning voltage. Adjust for 120MHz [115MHz]. ($V_t = 7V$)

Adjust the Bragg angle (gently rotate the AOD) to achieve the best efficiency in the first order. THEN adjust the RF power to maximize this efficiency. Typical values should approach 90%. Reduce power to give 95% of this peak value.

The next steps optimize the Bragg angle to achieve the flattest efficiency across a 50MHz scan. This is achieved by alternating between two frequencies towards the extremes of the scan range and making fine adjustments to the Bragg angle. These balance points are made 5MHz in from the absolute maximum scan limits However when balanced the result should give 1st order diffraction efficiencies approaching 80% across the full 50MHz.

Thus to maximize and balance the efficiencies at both 90 and 130MHz. [85 and 125MHz]

- 4: Set the tuning voltage V_t at 9.0V for 130MHz [125MHz]. Note the efficiency
- 5: Set the tuning voltage V_t at 1.0V for 90MHz [85MHz] Note the efficiency
- 6: Make fine adjustments to the Bragg angle and if necessary make incremental increases in RF power to achieve > 75% at these points and an efficiency balance within 5%

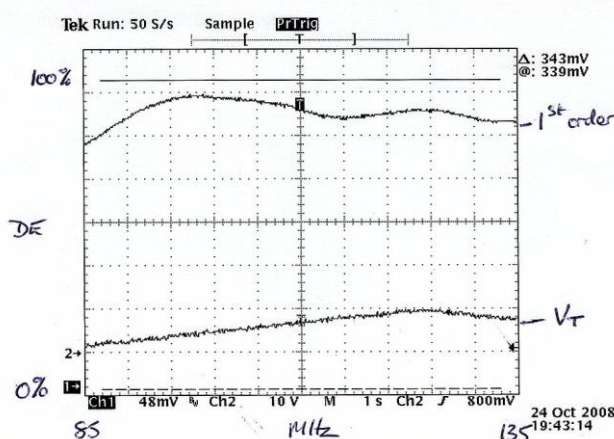

A typical scan response.