

iMS4-L -xxx (revB) Modular Quad Output Synthesizer

Overview and Basic Operation

Models -

Model	Outputs	Feature	Frequency	RF Output
			Range (MHz)	Power
iMS4-L	4	Standard model	12.5 – 200MHz	1.2mW
iMS4-L-Fx2	4	Integrated Frequency doubling stage	150 - 400MHz	50mW

Options –xxx, combinations possible

ISOMET CORP, 10342 Battleview Parkway, Manassas, VA 20109, USA.
Tel: (703) 321 8301, Fax: (703) 321 8546, e-mail: isomet@isomet.com
www.ISOMET.com
ISOMET (UK) Ltd, 18 Llantarnam Park, Cwmbbran, Torfaen, NP44 3AX, UK.
Tel: +44 1633-872721, Fax: +44 1633 874678, e-mail: isomet@isomet.co.uk



Contents

1. Hardware Overview and Key features.	3
2. Single (Set Calibration) Tone.....	5
3. Local Tone Buffer.....	6
4. Enhanced Tone Mode.....	6
5. Image Mode.....	8
6. Look-up-table (LUT).....	8
7. RF power Level and Modulation.....	9
8. Technical Specifications.	10
9. Hardware Connection.	12
10. LED Indicators.....	14
11. Connector pin-outs.....	15
13. Software.	21
14. Direct programming of the DDS Synthesizer Chip.....	27

Supporting Documents:

Isomet iMS4 GUI Software Guide

Compensation LUT Explanation and Generation Guide

1. Hardware Overview and Key features.

The diagram below illustrates a schematic of the iMS4-L connected with a generic Power Amplifier **Before** operating the IMS4-L, it will be necessary to load the USB Window drivers. (See section 10). The IMS4-L operates from DC power and requires a 15V-24Vdc supply (0.7Aat 24Vdc)

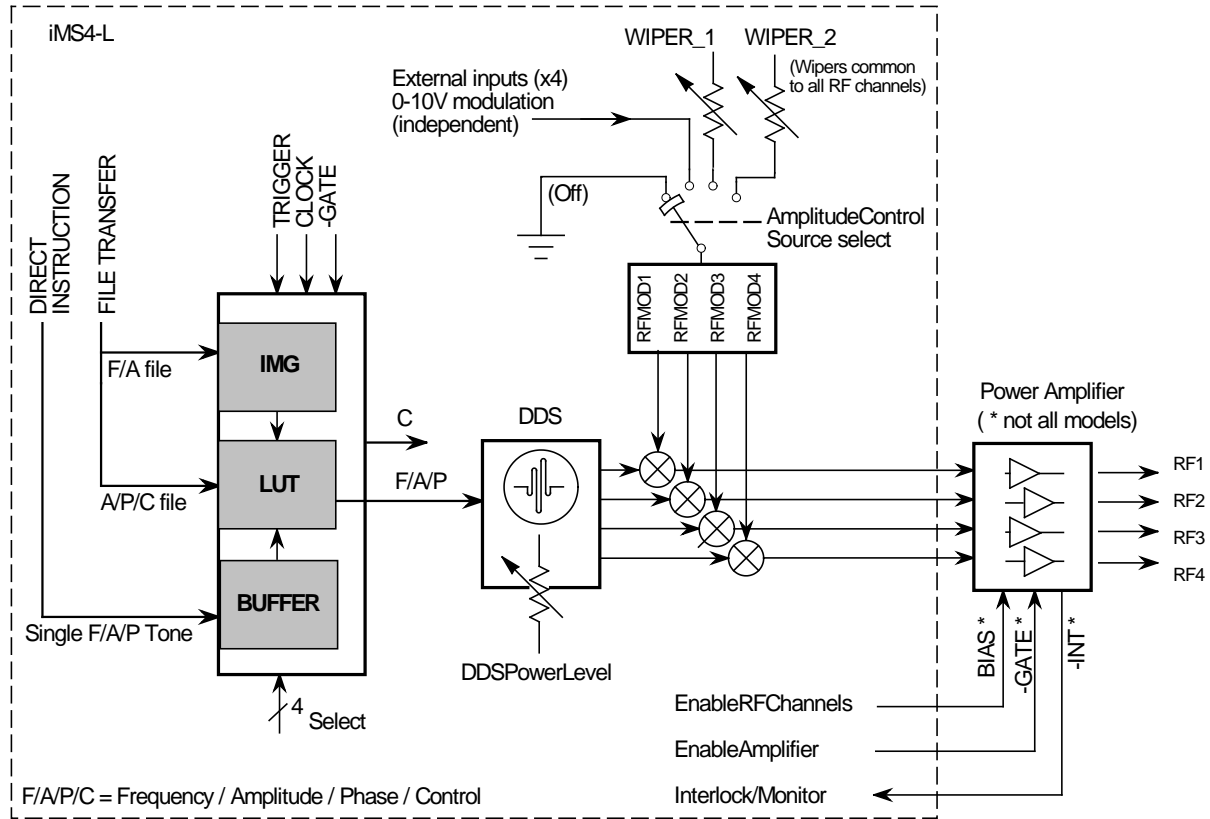

Conceptual diagram for iMS4-L with PA

The iMS4 synthesizer operates in three basic modes

1.1 Local Tone Buffer (LTB) or Single Tone Mode.

This mode is useful for setting the AO Bragg Angle or switching rapidly between 256 preassigned points. The DDS synthesizer generates a single tone output at the specified Frequency, Amplitude and Phase or F/A/P triad.

Key features:

- Up to 95 KHz update rate.
- The required output tone may be selected via software control or from hardwired inputs.
- Option to bypass the LUT modifier (see LUT description below)

1.2 IMAGE mode or Sequence mode.

This mode is useful for generating larger more complex scan patterns.

An Image file (IMG) containing the desired frequency scan pattern is downloaded into memory space within the iMS4-L. Output play back is under the control of user defined Image Trigger and Image Clock.

Key features:

- Update rate up to 330KHz, all four channels.
- Any frequency pattern may be generated e.g. random, linear, step, saw tooth.
- Image may contain up to 4096 frequency points across 4 outputs.
i.e. 1024 points if all four outputs are programmed. (For larger capacity, see iMS4-P)

LUT and Image files can be generated on Excel Spread sheets and imported into the C++ project.

1.3 Enhanced tone mode (Ramp / Step mode)

This mode uses the inherent sweep functions built into the DDS chip. Frequency, amplitude** or phase can be ramped in value.

Control Features

Look-up-table (LUT)

A calibration or compensation look-up-table (LUT) contains frequency specific phase and amplitude data. Its purpose is to compensate for non-linearity and non-uniformities in the wider system. E.g. create efficient uniform intensity scan lines in an AOD base laser scanning system.

Initial values for the LUT are calculated and loaded into the IMS prior to running the Local Tone Buffer or Image modes. Subsequently, LUT values may be modified with real world measured data or integrated within a feedback mechanism.



Amplitude and Power Level control

Each frequency point is assigned a unique 10-bit amplitude value ranging from 0 -100% of the maximum RF power setting. This is a relative value and is dynamic i.e. able to change from output point to output point.

The maximum RF output power setting is defined by the iMS AmplitudeControl and DDSPowerLevel digital potentiometers. These are 8-bit static controls and together define the absolute RF power level of the IMS4-L (and any connected power amplifier module).

Auxiliary Digital and Analog I-O signals

The iMS-L also features:

<u>Signal Description</u>	<u>Ident</u>
12 bit Synchronous output register, updated with the each new image point,	SDOR[0...11]
10 bit Asynchronous output,	GP Out[1...10]
8 bit Asynchronous input,	GP In[1...8]
1 bit 24V PLC compatible opto relay output,	Laser bit
2x Synchronous analog outputs, 0 -5V full scale	AOUT_Frq ...Amp
1x Asynchronous analog output, 0 -10V full scale	AOUT_DAC
2x Asynchronous analog inputs, 0 -10V full scale	Aux_ADC1 ... 2

Main operating modes and functions.

Please refer to the application program interface (API) documentation with the software development kit (SDK) available as a download.

2. Single (Set Calibration) Tone.

Simplest mode.
Direct programming of the DDS frequency, amplitude and phase values.
Bypasses LUT compensation.

3. Local Tone Buffer.

The Local tone buffer (LTB) area contains a maximum 256 F/A/P locations.
The 256 F/A/P Tones may be rapidly addressed using 8x external LTB address lines or directly from the operating software.

LTB ext'l address, J8 (pins 3,4,5,6,16,14,7,8).	Function	Update rate
0 h ... FF h	Select Tone address	10.5usec

The compensation look up table (see below) may be applied to the Tone Buffer output if required.

4. Enhanced Tone Mode (Ramp / Step mode)

This mode uses the inherent sweep functions built into the DDS chip.

Frequency, amplitude** or phase can be ramped in value. For conciseness, only frequency ramps and steps will be described.

4.1 Ramp Mode

A ramp or chirp is generated by rapidly incrementing the frequency. The number of increment steps and duration of the ramp are user programmable. Each output can be programmed with different ramp parameters.

The ramps are initiated from the GUI or applying a signal to the external Profile inputs on connector J8

Available functions:

- Independent Up - Down ramp slopes.
- Dwell (stop at end value) or no-dwell (return to start value) at end of sweep duration.
- Set amplitude value for ramp. (remains constant for the ramp duration).

The Ramp mode offers the fastest frequency sweep capability, with a minimum dwell time of 8nsec per frequency increment.

Independent sliders for each of the four output channels define:

- Duration of the rising slope increment.
- Duration of the falling slope increment.
- The number of points for each ramp, up or down.

The falling slope only applies if 'Dwell' is selected in the **Mode** pull down menu.

A **Frequency Sweep no dwell** immediately returns to the start value after the end value has been reached

A **No-Dwell** sweep immediately returns to the **Start** slider value (S0) after the **End** slider value (E0) has been reached

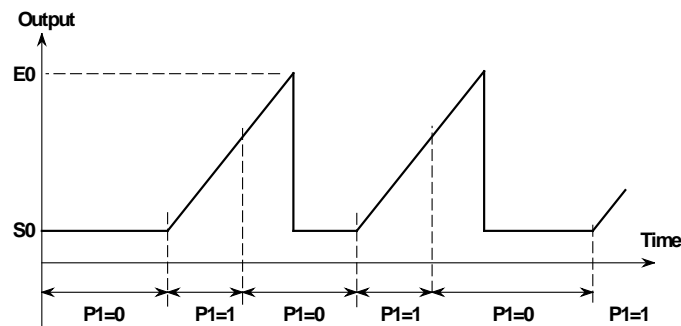

A **Frequency Sweep Dwell** only returns to the start value after a falling edge transition on the appropriate profile input

A **Dwell** sweep only returns to the **Start** slider value (S0) after a falling edge transition on the appropriate profile input

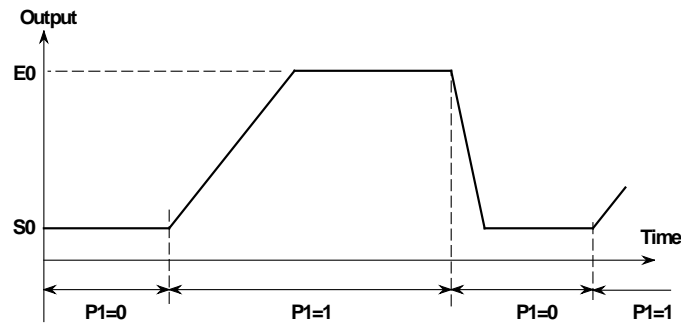

Both plots show a ramp on output J2, controlled using input P1

(**An internal limitation in the DDS chip prevents amplitude ramps in the Enhanced tone mode).

4.2 Step mode

This is essentially a two-level sweep or two-level modulation. Step mode may be applied to the Frequency, Amplitude or Phase. Dwell/No dwell has no function.

Plot shows a frequency step sweep for output J2 controlled using input P1.
 FREQ = Start Value
 CW1 = End Value

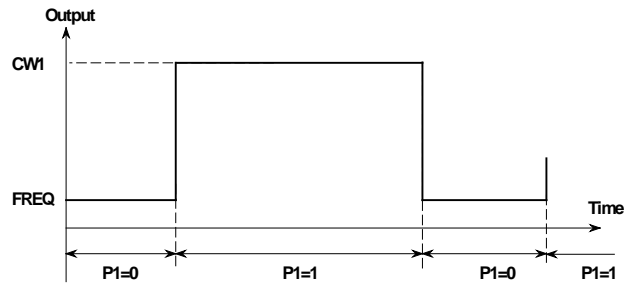

Amplitude

The amplitude level across a Frequency or Phase sweep (or step) remains a constant. The value is set by a combination of the **DAC Current** level buttons (Full, 1/2, 1/4, 1/8) and the sliders on the **Signal Path** panel.

5. Image Mode.

An Image contains multiple F/A/P data points pre-arranged to give the desired frequency or scan pattern. Image playback is initiated with the Image Trigger. The output update rate is determined by the Image Clock. The Image trigger and clock may be software generated or applied from an external source. At each clock edge, the next location in the Image Memory area is addressed. The frequency and amplitude data point is read and modified by the LUT data (see below). The resultant F/A/P triad is routed to the DDS registers. An update clock is then issued to the DDS and all 4x RF outputs are simultaneously updated with a new Frequency, Amplitude and Phase value. Any Synchronous control data will also be updated on the appropriate I/O port.

Multiple images can be grouped together into a play sequence. Each image within a sequence can have unique properties such as clock rate and post image delay. Likewise multiple sequences can be defined and queued. These are uploaded into the iMS DDR memory and played in FIFO order. Memory is dynamically allocated to permit flexibility in the size and number of both the images and sequences, and to allow simultaneous upload and output of data. The total number of images (excluding repeats) is 4096. The size of a single image is in excess of a 1million F/A/P points.

6. Look-up-table (LUT).

The LUT is frequency-addressed look-up-table for applying amplitude and phase compensation to the RF signal output. The tables are indexed by the nearest programmed LUT frequency to the demanded output frequency. Table entries are linearly spaced in frequency from the lowest to highest supported. The number of entries in the table is hardware specific. At a minimum, the LUT must contain amplitude compensation data over the desired frequency range of interest.

LUT Size: 2047 entries equally spaced from 12.5 – 200MHz.

Primary features: Compensation Data

- Amplitude: a value between 0 and 100% for modifying the output amplitude according to frequency. Used for compensating for AOD efficiency as well as filter attenuation and DDS roll-off.
- Phase: 0 - 360 degrees. Represents the per-channel phase difference applied to enable beam steered (= phased array) applications. Value represents the phase offset between adjacent channels Channel 1 is the reference and unmodified. Channel 4 will exhibit the largest phase differential relative to Channel 1.

Secondary features: Synchronous output data

- Sync Analog: A value between 0.0 and 1.0 that can be output on one of the synchronous DAC outputs (updated in step with the RF image point data).
- Sync Digital: A binary value that can be output on the synchronous digital outputs (updated in step with the RF image point data).

7. RF power Level and Modulation.

The output RF power at each frequency is determined by the combination of static controls and point specific amplitude data values.

Static Asynchronous Controls. Applies to all operating modes.

Purpose: To set the maximum safe operating RF power level.

- 1: DDS Power Level. 8-bit non-volatile digital pot. Always programmed.
Sets the DDS chip output level using a dedicated digital pot. Common to all outputs.
Typical values 50 – 90%

<< and >>

- 2: Amplitude Control Source for the RF mixers, 4 options. Must select and apply one.
- 00: OFF. Common to all outputs
01: EXTERNAL signal(s)*, per RF channel, output proportional to applied control voltage.
10: WIPER_1, internal 8-bit non-volatile digital pot setting. Common to all outputs
11: WIPER_2, alternative to Wiper_1

The value written and stored to Wiper_1 (or Wiper_2) sets the RF mixer drive level.
Typical values 50 – 100%

The above controls should be set in combination so that the AO device is operated at optimum efficiency without saturating the connected power amplifiers and/or applying excessive RF power to the AO device. Starting values will be provided on the appropriate test data sheets

(* Can be wired together to combine multiple channels onto a common control input.
0-10V, 600-ohm / channel. May also be used for fast asynchronous amplitude modulation).

Dynamic Synchronous Control.

Purpose: To set or modulate the RF power at a specific output frequency.
(i.e. to control the diffracted laser intensity at a specific scan angle)

- 3: Tone Buffer mode
The 10-bit amplitude data value associated with a specific frequency value. This is multiplied by the LUT amplitude calibration factor for that frequency point.

<< or >>

- 4: Image mode
The 10-bit amplitude data value associated with a specific frequency value. This is multiplied by the LUT amplitude compensation factor for that frequency point.

For a typical AO scanning application, the Image amplitude data is a simple “On” or “Off” value. The LUT is programmed with the variable amplitude compensation data that creates the desired weighting for the scan intensity profile.

In both cases, the LUT can be bypassed if required. The LUT is applied by default.

8. Technical Specifications.

Image Mode

Timing	Value	Condition
Frequency Settling Time	< 40nsec	Step change in Image data value (Phase accumulator set to clear at each DDS update)
Output Delay to Image Clock edge	1.6 usec	* 0.25usec
Minimum Trigger to Clock edge	TBD nsec	
Maximum Image Clock rate	300 KHz	* 1MHz (See iMS4-P)
Minimum Image Clock rate	0 Hz	

GATE, TRIGGER, CLOCK inputs. J9, J10, J11	Value	Condition
Absolute Maximum Input Voltage	5.5V	Per input.
Recommended Input Voltage	> 3V, <5V	For logic High
Minimum Input Voltage	0V	

Active edge of the external Clock or Trigger inputs is user programmable . Default = rising

* Future planned optimization. Please contact Isomet

Local Tone Buffer Mode

Timing	Value	Condition
Frequency Settling Time	< 40nsec	For tone – tone selection (Phase accumulator set to clear at each DDS update)
Output Delay - LTB address change	6 usec	
Maximum LTB address rate	95KHz	
Minimum LTB address rate	0 Hz	

LTB address, input Voltages, J8	Value	Condition
Absolute Maximum Input Voltage	5.5V	Per input.
Recommended Input Voltage,	> 3V, < 5V	For Logic High
Minimum Input Voltage	0V	
Opto-isolated, signal source sink current	16mA	Per input

External Modulation Inputs, J8

Parameter	Value	Condition
RF output Rise time	< 40nsec	Step change in external modulation input
Output Delay - Modulation input	50nsec	Step change in external modulation input
Absolute Maximum Input Voltage	12V	Per input.
Recommended Input Voltage	10V	
Minimum Input Voltage	0V	
Input impedance	~600Ω	Per input
On:Off ratio	> 35dB	Full range
Maximum modulation rate	10MHz	
Minimum modulation rate	0 Hz	

RF power control, SDK

Max – Min	Full Range	Condition
DDS Power Level	8dB	All other variables at max power
Amplitude Control Source : Wiper_1, _2 or Ext'l	39dB	
Image or LTB Amplitude data	48dB	10bit range

RF outputs, J1,J2,J3,J4

RF Output	Full Range	Condition
Maximum output power	> 1.2mW / 0.8dB	At 80MHz,
Frequency Stability	25ppm	-40C to +85C
Spurious output	> 40dBc	
Harmonics	> 25dBc	At 1mW output
Channel to Channel Isolation	> 43dB	At 1mW output

9. Hardware Connection.

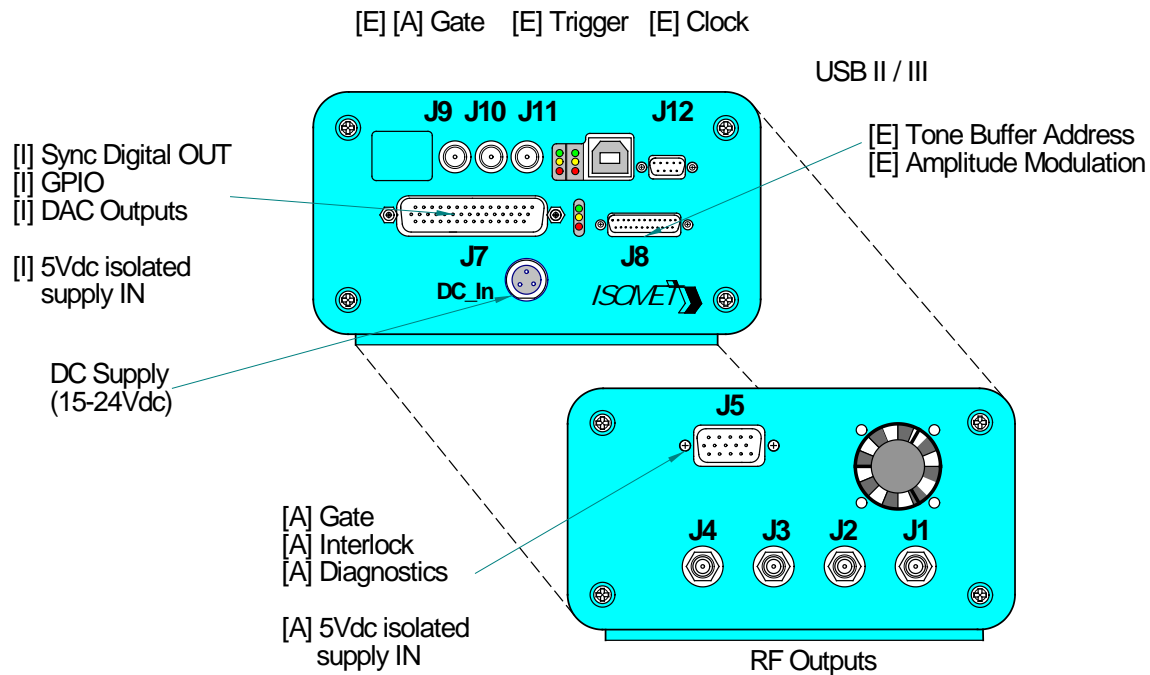

Minimum Connections:

- USB II or USB III to a host PC.
- DC Supply, 15V / 1A minimum to 24V / 0.5A maximum
- One or more RF outputs, as required.

Recommended channel connections

AOD / Amplifier Channels	iMS Outputs
Single	Any
Dual	J1, J2 or J3, J4
Quad	All, in ascending or descending order

Optional connections are identified as follows:

[E] = hardwired control signals from external signal source(s).

Functionally equivalent software generated control signal are provided in the SDK.

[I] = opto-isolated IO buffered signals requiring an external 5Vdc supply connection to J7 or J8

[A] = external power amplifier connections (see explanation below)

The iMS4-L features external power amplifier diagnostic and control signals.

These are available on J5. J5 will require 5V opto isolator dc feed (5V_RFA) from the connected RF amplifier. An appropriate interface card must exist within the power amplifier.

Basic amplifier control

With few exceptions, most Isomet existing power amplifier modules require an active low Gate or Enable signal to operate and will output a normally closed over-temperature thermal interlock signal.

Diagnostics

Certain amplifier models include diagnostic outputs indicating:

- Forward and reflected RF power (between the PA outputs and connected AO device/load).
- Temperature of the PA
- DC current
- Temperature of the AO device

These are communicated via I2C bus on J5 .

Examples include:

Model	Channels	Power/ch	Frequency Range	Enable/Gate Control	Diagnostics
500C series	1	2,4, or 7W	Model dependent	NA	NA
800PC-f/f/f/f	4	1W	Model dependent	NA	NA
RFA200-2H	2	100W	35 – 65	J5	NA
RFA1170-4	4	80W	48-92	J5	J5
RFA0110-2-20	2	20W	90-130	J5	J5
RFA0120-4-15	4	15W	100-120	J5	J5

NA= not applicable

10. LED Indicators.

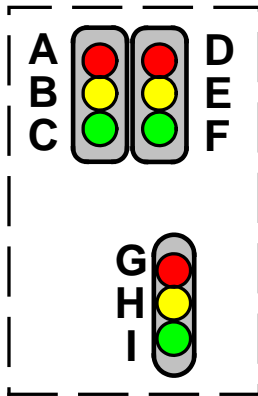

Top Stack, Controller PCB

Ident	LED	Mode	iMS4-L
A	RED (top left)	If illuminated	Not Downloading File
B	Yellow	If illuminated	Downloading File
C	Green	Pulsing	Controller OK
D	RED (top right)	If illuminated	Image output stopped
E	Yellow	If illuminated	Waiting on Trigger
F	Green	If illuminated	Image playing / output active

Lower stack. Synthesizer PCB

Ident	LED	Mode	Stand Alone iMS4-	In combination with PA and J5 is connected
G	RED (top)	Constant on	DC power On	Thermal Interlock Open (= fault)
H	Yellow	Constant on	NA	PA is enabled. Thermal Interlock OK
I	Green	Pulsing	Synthesizer OK	Synthesizer OK

DC power applied, USB communication problem

If the 6x LED's (A,B,C,D,E,F) are constantly illuminated, then USB communication has not been established. In this case:

- a: Ensure USB driver is loaded (see section 10)
 - b: Cycle DC power
- and /or
- c: Disconnect then reconnect USB

11. Connector pin-outs.

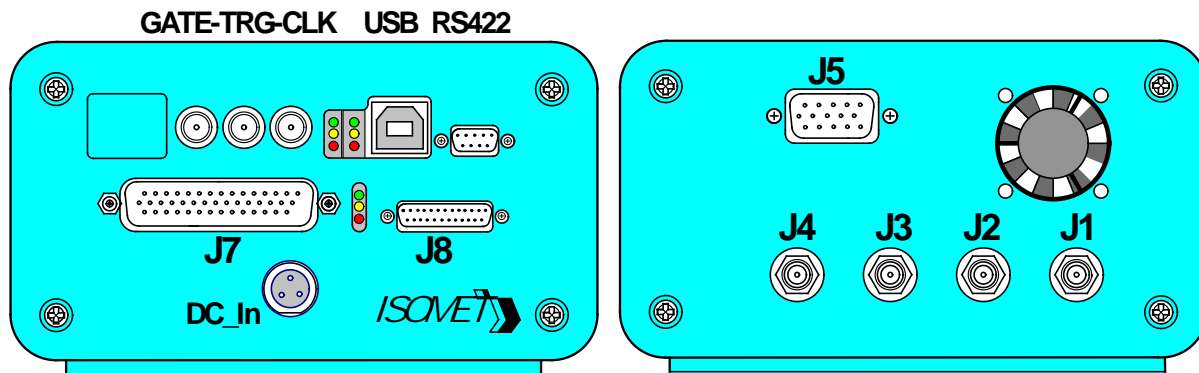

D-type pin ids looking into connector

Front panel view

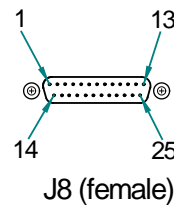
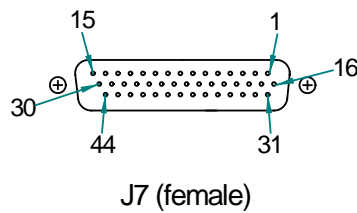

Pin-out descriptions as follows:

Circuit details for opto-isolated inputs / outputs on J7 and J8 connector

Recommended drive circuit for opto-isolated logic inputs

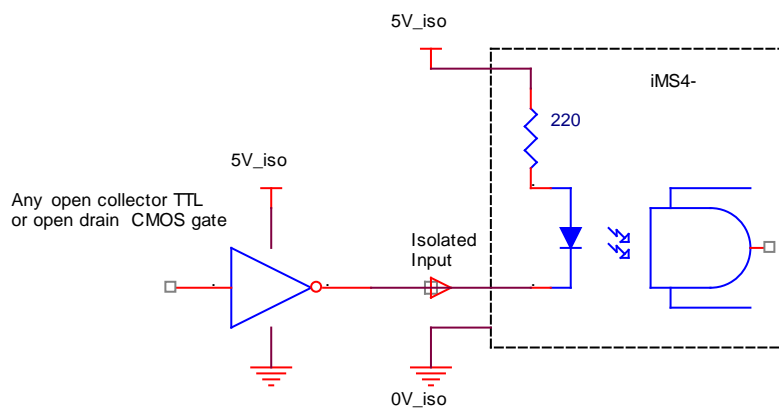

Opto-isolated logic output schematic

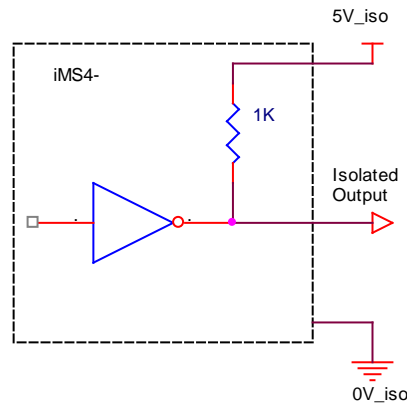

J8, 25way micro-D connector

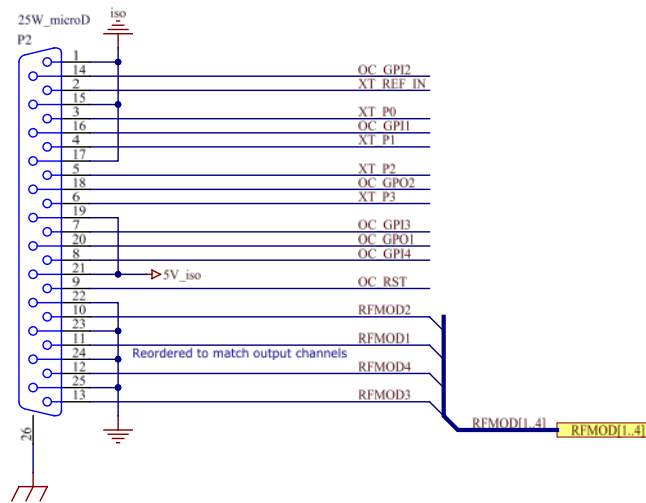

Main connection for external control signals
(Micro-D to full size D-type converter cable available).

Connector	Type	25way micro-D			
	Ident	J8			
Signal	Signal	Type	Description	Alternate use	Pin
Designation					
RFmod4	In	Analog, 0-10V	External amplitude control for RF4		12
A_Rtn		Analog	Analog return		24
RFmod3	In	Analog, 0-10V	External amplitude control for RF3		13
A_Rtn		Analog	Analog return		25
RFmod2	In	Analog, 0-10V	External amplitude control for RF2		10
A_Rtn		Analog	Analog return		22
RFmod1	In	Analog, 0-10V	External amplitude control for RF1		11
A_Rtn		Analog	Analog return		23
RST	In	Opto isolated logic	Reset		9
REF_IN	In	Opto isolated logic	Reference Frequency (Optional)		2

GP I1	In	Opto isolated logic	Async general purpose input	LTB location/address, bit4	16
GP I2	In	Opto isolated logic	Async general purpose input	LTB location/address, bit5	14
GP I3	IN	Opto isolated logic	Async general purpose input	LTB location/address, bit6	7
GP I4	In	Opto isolated logic	Async general purpose input	LTB location/address, bit7	8
GP O1	Out	Opto isolated logic	Async general purpose output		20
GP O2	Out	Opto isolated logic	Async general purpose output		18
D_Rtn	DC		isolated 0V / signal return input	0V	17
P0	In	Opto isolated logic	Profile select, bit0	LTB location/address, bit0	3
P1	In	Opto isolated logic	Profile select, bit1	LTB location/address, bit1	4
P2	In	Opto isolated logic	Profile select, bit2	LTB location/address, bit2	5
P3	In	Opto isolated logic	Profile select, bit3	LTB location/address, bit3	6
D_Rtn	DC		isolated 0V / signal return input	0V	1
D_Rtn	DC		isolated 0V / signal return input	0V	15
5V_iso	DC		Isolated 5V DC supply input	5V output, 10mA	19
5V_iso	DC		Isolated 5V DC supply input	5V output, 10mA	21
D_Rtn	DC		isolated 0V / signal return input	0V	17
Notes:				Key:	
Type Logic = TTL or 5V CMOS				GP = General Purpose	
Drive inputs with open collector or open drain gate, 16mA sink				LTB = Local Tone Buffer	
Open collector outputs with internal 1Kohm pull-up to 5V_iso					

J7, 44way high density-D connector
 Connection for auxiliary I-O signals

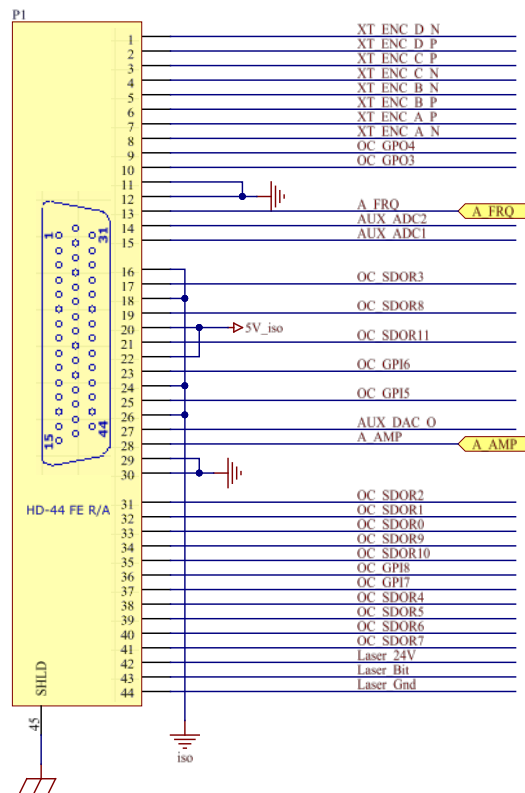

Connector	Type Ident	44way HD-D J7			
Signal Designation	Signal	Type	Description	Alternate use	Pin
SDOR0	Out	Opto isolated logic	Synchronous-Digital Output bit0		33
SDOR1	Out	Opto isolated logic	Sync-Digital Output bit1		32
SDOR2	Out	Opto isolated logic	Sync-Digital Output bit2		31
SDOR3	Out	Opto isolated logic	Sync-Digital Output bit3		17
SDOR4	Out	Opto isolated logic	Sync-Digital Output bit4		38
SDOR5	Out	Opto isolated logic	Sync-Digital Output bit5		39
SDOR6	Out	Opto isolated logic	Sync-Digital Output bit6		40
SDOR7	Out	Opto isolated logic	Sync-Digital Output bit7		41
SDOR8	Out	Opto isolated logic	Sync-Digital Output bit8		19
SDOR9	Out	Opto isolated logic	Sync-Digital Output bit9		34
SDOR10	Out	Opto isolated logic	Sync-Digital Output bit10		35
SDOR11	Out	Opto isolated logic	Sync-Digital Output bit11		21
D_Rtn	Out		isolated 0V / signal return input	0V	26
DL4_N	In	5V differential logic			1
DL4_P	In	5V differential logic			2
DL3_P	In	5V differential logic			3
DL3_N	In	5V differential logic			4
DL2_N	In	5V differential logic			5
DL2_P	In	5V differential logic			6
DL1_P	In	5V differential logic			7
DL1_N	In	5V differential logic			8
D_Rtn	In	(5V_iso supply required)	isolated 0V / signal return input	0V	16
GP I5	In	Opto isolated logic	Asynchronous GP logic input		25
GP I6	In	Opto isolated logic	Async GP input		23
GP I7	In	Opto isolated logic	Async GP input		37
GP I8	In	Opto isolated logic	Async GP input		36
GP O3	Out	Opto isolated logic	Async GP logic output		9
GP O4	Out	Opto isolated logic	Async GP output		10
D_Rtn	Out		isolated 0V / signal return input		24
24V_laser	In	PLC	Laser Opto-Supply		42
Laser_Bit	Out	PLC	Laser Opto relay bit Tr/Tf < 50usec)		43
Gnd_laser	In	PLC	Laser Opto-Gnd		44
AOUT_Frq	Out	Analog	8-bit analog representation of Image freq		13
AOUT_Amp	Out	Analog	8-bit analog equivalent of Image amplitude		28
A_Rtn	Out	Analog	Analog return		30
AOUT_DAC	Out	Analog	GP 12-bit DAC analog output.		27
A_Rtn	Out	Analog	Analog return		29
Aux_ADC1	In	Analog	GP Analog input to a 12-bit ADC (0 to 10V).		15
A_Rtn	In	Analog	Analog return		11
Aux_ADC2	In	Analog	GP Analog input to a 12-bit ADC (0 to 10V).		14
A_Rtn	In	Analog	Analog return		12
5V_iso	DC		Isolated 5V DC supply input	5V output, 10mA	22
5V_iso	DC		Isolated 5V DC supply input	5V output, 10mA	20
D_Rtn	DC		isolated 0V / signal return input	0V	18
Notes:				Key:	
Type Logic = TTL or 5V CMOS				GP = General Purpose	
Drive inputs with open collector or open drain gate, 16mA sink					
Open collector outputs with internal 1Kohm pull-up to 5V_iso					

Other Connectors

Connector	Type Ident	see table see table						
<u>Signal Designation</u>	<u>Signal</u>	<u>Type</u>	<u>Description</u>	<u>Alternate use</u>	<u>Connector</u>	<u>Ident</u>	<u>Pin</u>	
			Communication					
NOT USED	na	na	na		RJ45			
USB Serial	In/Out	Logic	USB II / USBIII		B-type	-		
RX-P	In	Logic	RS422 receive+		9-way D	J12	2	
RX-N	In	Logic	RS422 receive-		9-way D	J12	1	
TX-P	Out	Logic	RS422 transmit+		9-way D	J12	7	
TX-N	Out	Logic	RS422 transmit-		9-way D	J12	6	
Rtn	Gnd		Sig Rtn		9-way D	J12	5	
			DC Supply					
Vdc	DC	DC-In	Supply 15V -24V dc, <0.4A		3w TINI-Q		1	
	0V	DC-In			3w TINI-Q		2	
			SMA Coax Connections					
Gate	In	Logic	Enable power amplifiers via J5	POF input	SMA coaxial	J9	Centre	
Rtn	Gnd		Sig Rtn				Outer	
Trigger	In	Logic	Trigger Image Data Output	POF input	SMA coaxial	J10	Centre	
Rtn	Gnd		Sig Rtn				Outer	
Clock	In	Logic	Clock Image Data	POF input	SMA coaxial	J11	Centre	
Rtn	Gnd		Sig Rtn				Outer	
Ch0	Analog	RF	RF1 frequency output, 50Ω		SMA coaxial	J1	Centre	
Rtn	Gnd		Sig Rtn				Outer	
Ch1	Analog	RF	RF2 frequency output, 50Ω		SMA coaxial	J2	Centre	
Rtn	Gnd		Sig Rtn				Outer	
Ch2	Analog	RF	RF3 frequency output, 50Ω		SMA coaxial	J3	Centre	
Rtn	Gnd		Sig Rtn				Outer	
Ch3	Analog	RF	RF4 frequency output, 50Ω		SMA coaxial	J4	Centre	
Rtn	Gnd		Sig Rtn				Outer	
			J5 Power Amp Control *					
5V_RFA	In		Opto supply from connected PA	5V, 20mA out	15w-HD D	J5	1	
5V_RFA	In		Opto supply from connected PA	5V, 20mA out	15w-HD D	J5	10	
0V_RFA	In		Opto 0V from connected PA	0V	15w-HD D	J5	4	
0V_RFA	In		Opto 0V from connected PA	0V	15w-HD D	J5	7	
SCL_RFA_TX	IO	Opto isolated logic	I2C Clock_TX		15w-HD D	J5	2	
SCL_RFA_RX		Opto isolated logic	I2C Clock_RX		15w-HD D	J5	3	
SDA_RFA_TY	IO	Opto isolated logic	I2C Data_TY		15w-HD D	J5	5	
SDA_RFA_RY		Opto isolated logic	I2C Data_RY		15w-HD D	J6	6	
EXT-CONVST	Out	Opto isolated logic	Start ADC conversion		15w-HD D	J5	8	
-EXT_GATE	Out	Opto isolated logic	Enable connected amplifier		15w-HD D	J5	9	
EXT-BSY	In	Opto isolated logic	ADC conversion busy		15w-HD D	J5	11	
EXT-INT_MON	In	Opto isolated logic	Interlocks valid monitor		15w-HD D	J5	12	
			* Applies only when signals supported by connected PA					

12. Signal Timing Diagram

Applies to Image mode

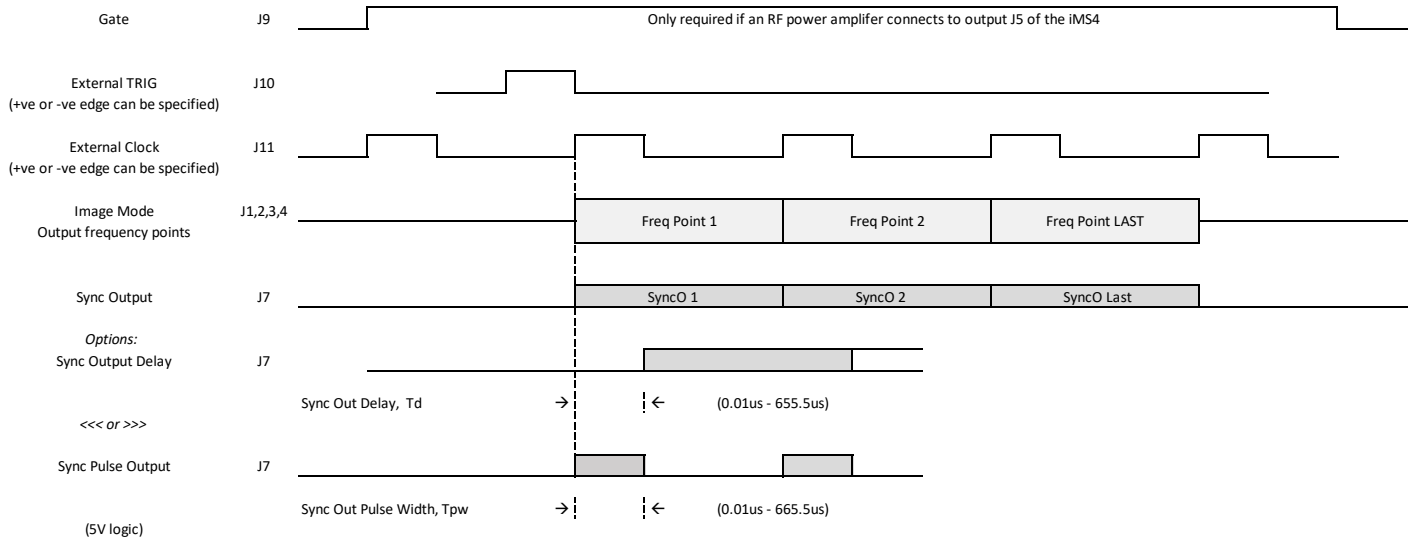

13. Software.

The core of the Software Development Kit is the C++ iMS library and API. All interaction with iMS hardware ultimately passes through this API. However we have also provided a number of other software utilities and wrappers that allow you to use the iMS System at a higher level of abstraction.

Included in the SDK are:

- The core iMSLibrary binaries for a number of different platforms and toolsets.
- Accompanying C++ header files for application interface.
- iMSNET An experimental .NET assembly written in C# that wraps the core library and permits user application development in any .NET language targeting the .NET Framework
- ims_hw_server is a command line daemon type process that can handle all communication with an iMS system, decoupling it from user application business logic. A gRPC streaming interface connects the server to application software, either on the same host or across a network.
- iMS Studio is a full featured GUI front end application that can be used to create Images, Tone Buffers and Compensation Functions and play them on an iMS system. This is often a good starting point for users wishing to explore the capabilities of an iMS before starting development of custom software.**

The iMS software is available for download from <http://www.isomet.com/software.html>

Depending on your computer select and run one of the following :

Isomet iMS SDK v 1.xx Win7 Setup.exe
Isomet iMS SDK v 1.xx Win10 Setup.exe

The software download also includes documentation and tutorials for setting up a project and connecting to the iMS. Note: these Tutorials are NOT specific to any practical AO device.

Please refer to **Quick Start Guide: Isomet iMS Studio** for instructions on the Isomet Windows GUI

The iMS software library and API has been written purely in native ANSI-C++ with some use of features introduced in C++11 (ISO/IEC 14882:2011), including the C++ Standard Library. There is no use of features associated with the updated C++14 specification.

Isomet will provide example projects applicable to the customer hardware configuration.

The Software Development Kits are regularly updated. Please check for Isomet website for updates.

a. Visual Studio Notes

	Visual Studio 2013 (v120)		Visual Studio 2015 (v140)	
	32-bit	64-bit	32-bit	64-bit
Microsoft Windows 2000/XP/Vista or earlier	✘	✘	✘	✘
Microsoft Windows 7 Professional	✔	✔	✔	✔
Microsoft Windows 8/8.1	⚠	⚠	⚠	⚠
Microsoft Windows 10 Professional	✘	✘	✔	✔

Table 1 Toolset Version Compatibility Table

b. Folder locations.

For ease of installation, a C++ console application template file is provided.

Copy the file *iMSTemplateWin7VC140.zip* into the Visual Studio project templates folder e.g. C:.....Documents > Visual Studio 2015 > Templates > ProjectTemplates

DO NOT unzip

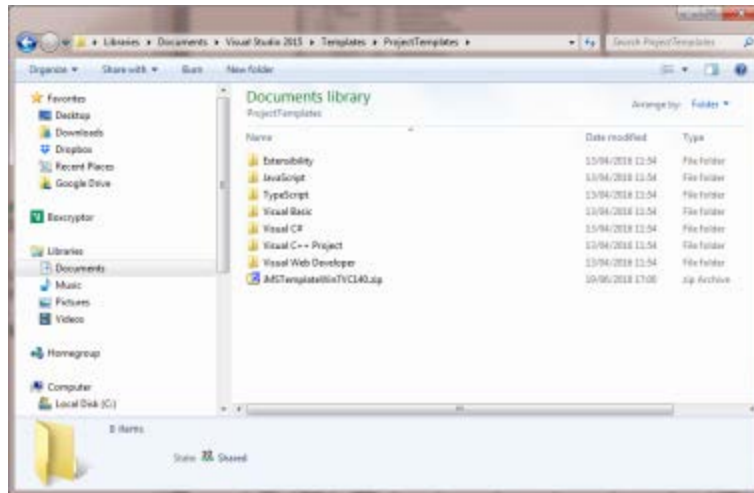

When starting *New Project* from Visual Studio, the *iMS Console Application* will be offered Edit the Name and project Location as required

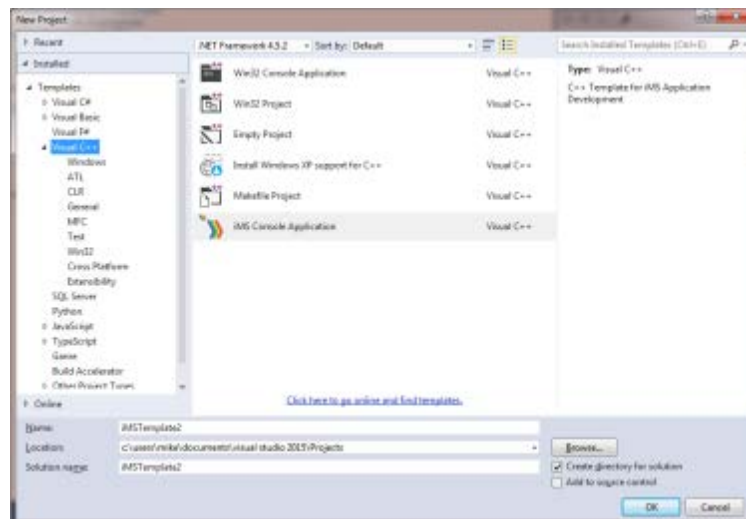

c. Adding C++ code to the project template

Please refer to the comments within the C++ template code and the ReadMe.txt file

The application includes the example code necessary for connection to the iMS4 (via selected ports) and files which are used to build a precompiled header (PCH) file; StdAfx.h, StdAfx.cpp

Add additional include files to **StdAfx.h** only

```

StdAfx.h <- x iMS4EncoderDemo.cpp
1 // StdAfx.h : include file for standard system include files,
2 // or project specific include files that are used frequently, but
3 // are changed infrequently.
4 //
5
6 #pragma once
7 // These are the API header files we will need
8
9
10 #include "ConnectionList.h"
11 #include "iMSSystem.h"
12 #include "SystemFunc.h"
13 #include "ImageOps.h"
14 #include "Conversation.h"
15 #include "SignalPath.h"
16 #include "ToneBuffer.h"
17 #include "SystemFunc.h"
18 #include "IMSTypeDefs.h"
19 #include "libsl.h"
20
21 #include <stdio.h>
22 #include <stdlib.h>
23 #include <iostream>
24 #include <fstream>
25 #include <threads>
26 #include <vector>
27 #include <conio.h>
28
29
30 // TODO: reference additional headers your program requires here
31
32

```

Referencing the default Source file (e.g. iMSTemplate.cpp)

User application code is added from line 111

```

iMSTemplate2.cpp <- x StdAfx.h
108
109     if ((ch - '0') > 0 && (ch - '0') <= (int)(fullIMSList.size())) {
110         myIMS = fullIMSList[ch - '0'];
111         break;
112     }
113     std::cout << std::endl;
114 }
115
116 std::cout << "Connecting ... ";
117 myIMS->Connect();
118 std::cout << "OK" << std::endl;
119
120 // Application Code goes here
121 //
122 //
123 // CLEANUP
124 //
125 myIMS->Disconnect();
126 std::cout << "Press a key to exit..." << std::endl;
127 while (!_kbhit());
128
129 return 0;
130
131
132

```

d. Installing the 3rd party Excel Spreadsheet Import Export function

Generating Compensation Tables (LUTs) and Image files in Excel can be convenient.

Several routines exist to import data into C++. One such is from libxl.com

A licence key is required and it is free to use.

Add the following code prior to calling the LibXL functions.

```
// call LibXL licence key
libxl::Book* ExcelBook = xlCreateBook();
ExcelBook->setKey(L"Michael Hillier", L"windows-222329040ec5ec046fb46767a7h1gej6");
```

To add this feature to your project

Create a folder Excel-DLL_LIB in the Projects folder and download associated files (contact Isomet)

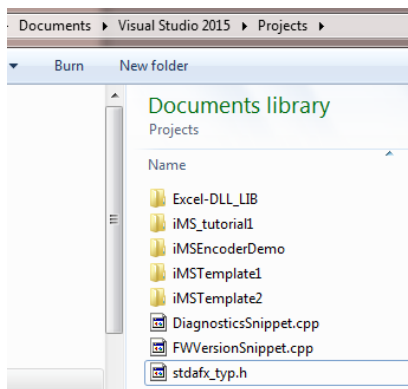

- Add the above additional include files to **StdAfx.h** only

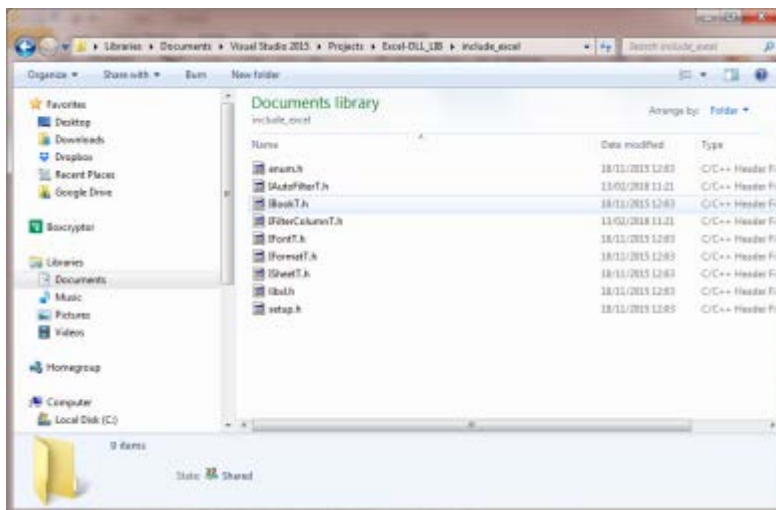

Add 'include_excel' to the above *Additional Include Directory* under *C++ > General*.

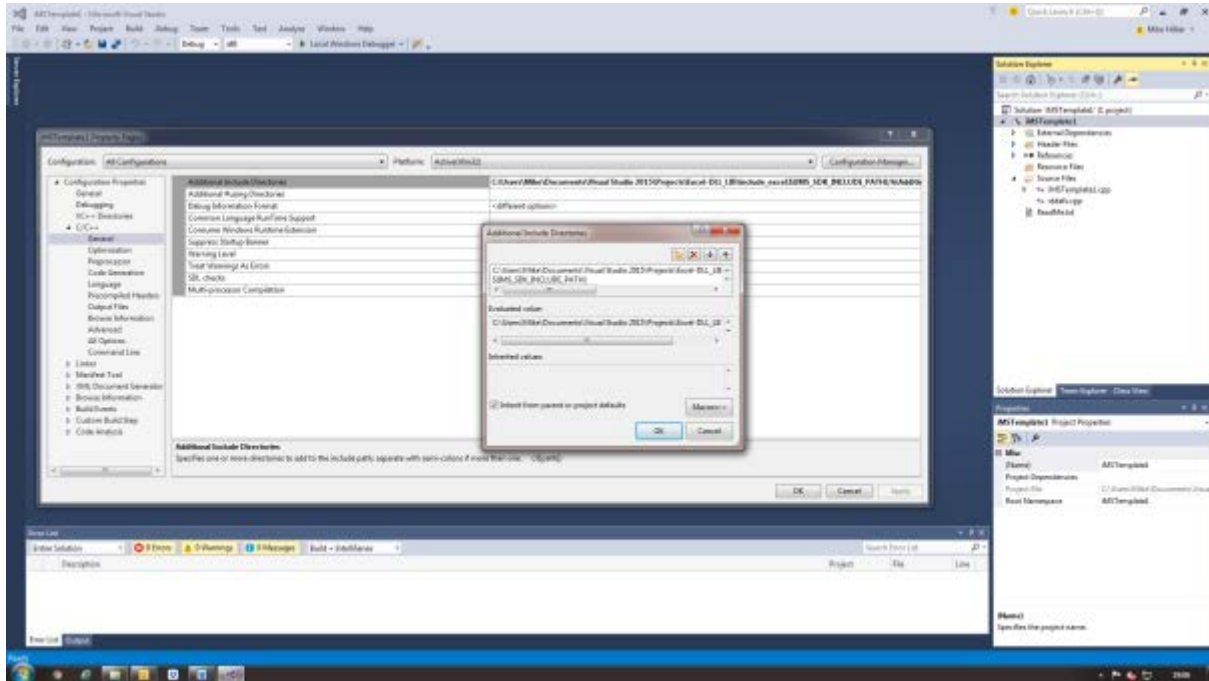

- Copy libxl.dll from > Excel_DLL-LIB > bin to the project folder you created.

It must be in the same folder as the source file *.cpp.

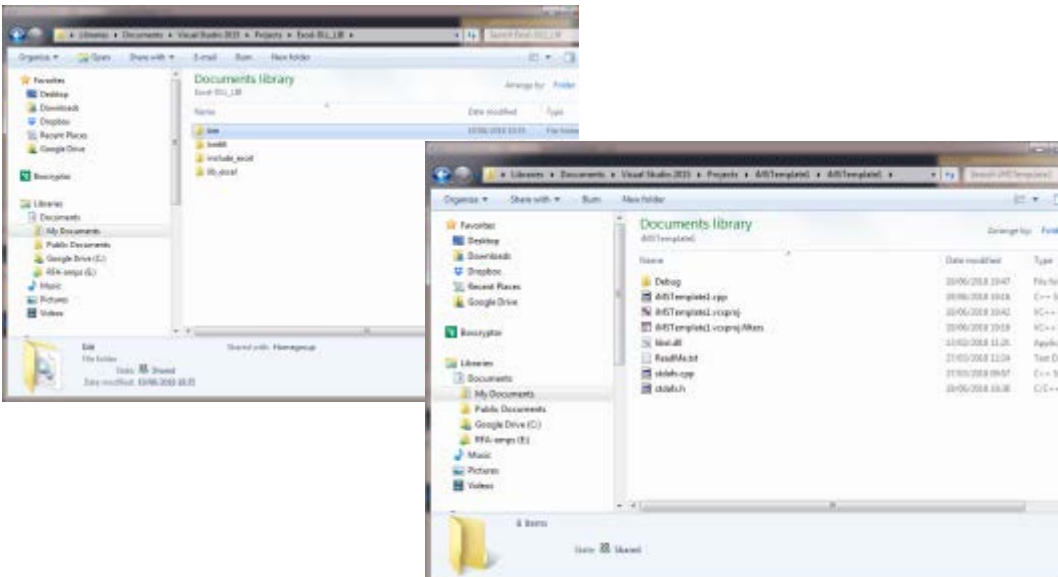

- Add the folder containing libxl.lib to the *Additional Library Dependencies* under *Linker > General*.

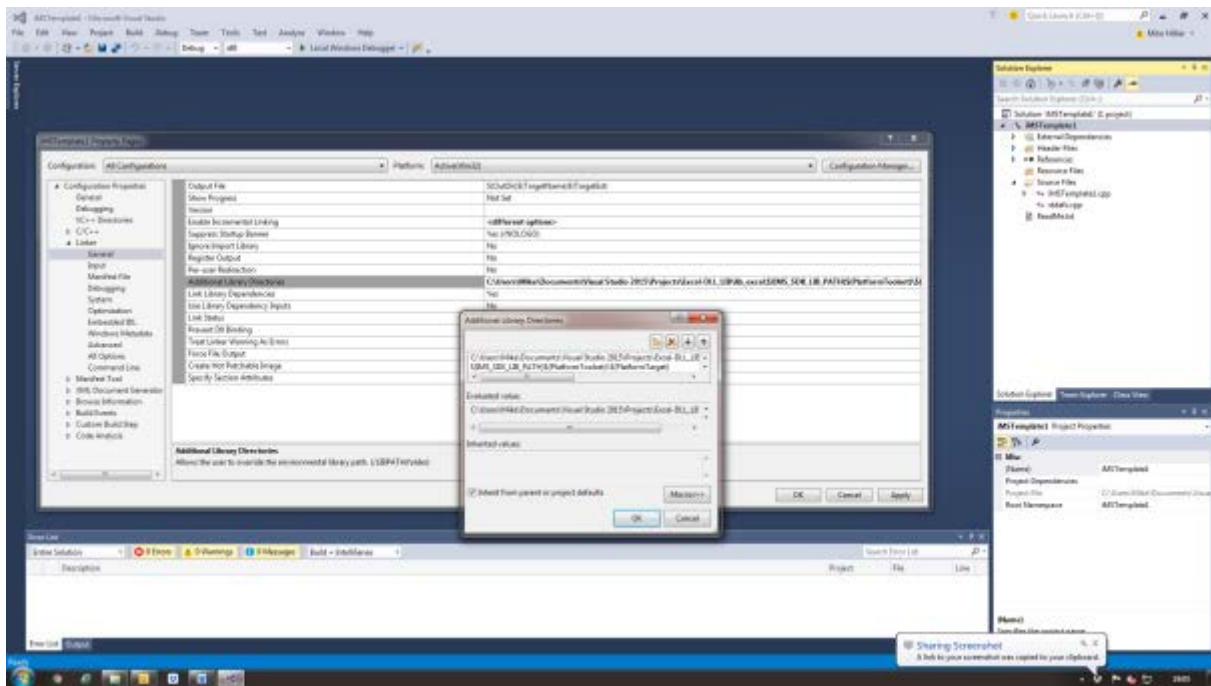

- Add libxl.lib to the *Additional Dependencies* under *Linker > Input*

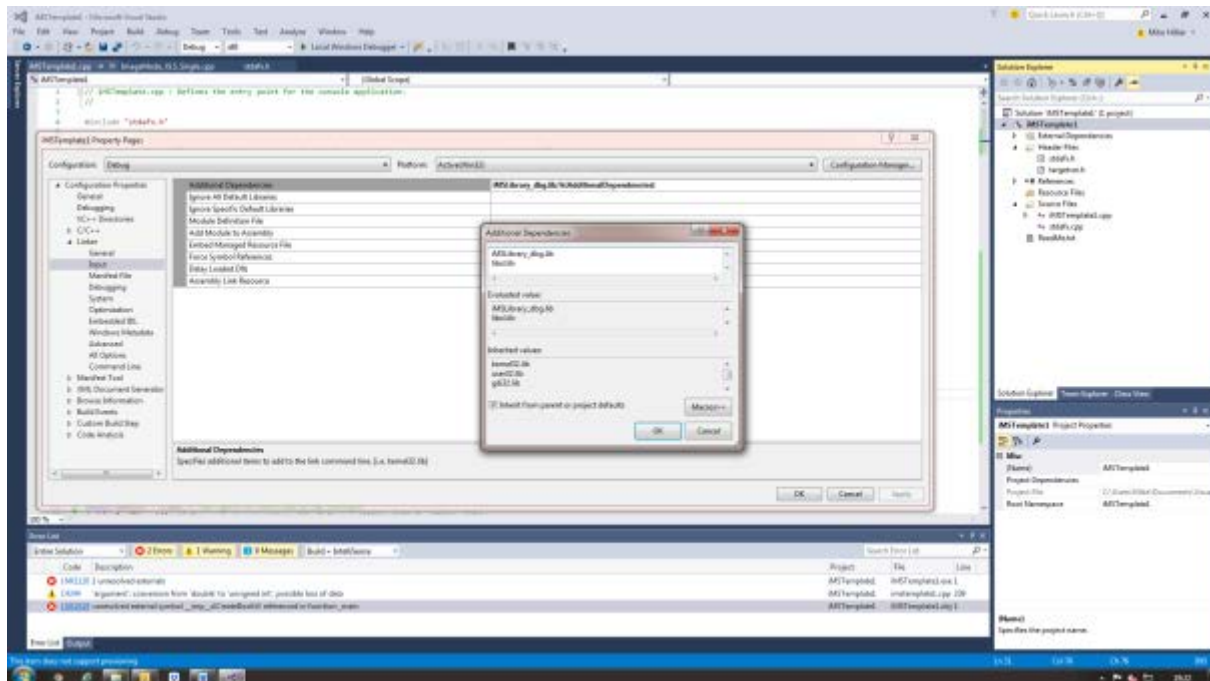

14. Direct programming of the DDS Synthesizer Chip.

For most applications, the use of the DDSscript function is not required.

Use with CAUTION

The DDS IC that generates the RF signals can be manually programmed to access advanced features that wouldn't normally be available through the iMS API. To do this requires a detailed knowledge and understanding of the Analog Devices AD9959 Frequency Synthesiser IC and its register map.

If it is necessary to manually program the AD9959, a sequence of register writes can be generated (called a DDS Script) and stored in the Synthesiser Filesystem. The application software may then recall the script from the filesystem and execute it to commit the register writes to the AD9959. Please refer to DDSscript Class description in the SDK documentation.

REGISTER MAPS

Each register write is initialised with the name of the register as the first argument. (This is in the same abbreviated form as specified in the AD9959 datasheet).

Control Register Map

Register Name (Serial Addr)	Bit Range	Bit 7 (MSB)	Bit 6	Bit 5	Bit 4	Bit 3	Bit 2	Bit 1	Bit 0 (LSB)	Default Value
Channel Select Register (CSR) (0x00)	[7:0]	Channel 3 Enable * (1 = On)	Channel 2 Enable *	Channel 1 Enable *	Channel 0 Enable *	Must be 0	Serial I/O mode Select [2:1] B2=1, B1=0		LSB first	0xF4 DO NOT CHANGE
Function Register 1 (FR1) (0x01)	[23:16]	VCO gain control	PLL divider ratio[22:18]				Charge pump Control [17:16]		0xD0	
	[15:8]	Open	Profile pin configuration (PPC) [14:12]			Ramp-up/down (RU/RD) [11:10]	Modulation level [9:8]		0x00	
	[7:0]	Reference clock input power-down	External power-down mode	SYNC_CLK disable	DAC reference power-down	Open [3:2]	Manual hardware sync	Manual sync	0x00	
Function Register 2 (FR2) (0x02)	[15:8]	All channels autoclear sweep accumulator	All channels clear sweep accumulator	All channels autoclear phase accumulator	All channels clear phase accumulator	Open [11:10]	Open [9:8]		0x20	
	[7:0]	Auto sweep sync enable	Multidevice sync master enable	Multidevice sync status	Multidevice sync mask	Open [3:2]	System clock offset [1:0]		0x00	

Defaults = Power -on hard coded DDSScript

* Channel enable bits do not require an I/O update to be activated.

These bits are active immediately after the byte containing the bits is written.

All other bits need an I/O update to become active.

These four channel enable bits are used to enable/disable any combination of the four channels.

The default is all four enabled.

Channel Register Map

Register Name (Serial Addr)	Bit Range	Bit 7 (MSB)	Bit 6	Bit 5	Bit 4	Bit 3	Bit 2	Bit 1	Bit 0 (LSB)	Default Value	
* Channel Function Register (CFR) (0x03)	[23:16]	Amplitude freq. phase (AFP) select [23:22]		Open [21:16]							0x00
	[15:8]	Linear sweep no-dwell	Linear sweep enable	Load SRR at I/O_UPDATE	Open [12:11]		Must be 0	DAC full-scale current		0x03	
	[7:0]	Digital power-down	DAC power-down	Matched pipe delays active	Autoclear sweep accumulator	Clear sweep accumulator	Autoclear phase accumulator	Clear phase Accumulator **	Sine wave output enable	0x00	
* Channel Frequency Tuning Word 0 (CFTW0) (0x04)	[31:24]	Frequency Tuning Word 0 [31:24]									0x00
	[23:16]	Frequency Tuning Word 0 [23:16]									N/A
	[15:8]	Frequency Tuning Word 0 [15:8]									N/A
	[7:0]	Frequency Tuning Word 0 [7:0]									N/A
* Channel Phase Offset Word 0 (CPOW0) (0x05)	[15:8]	Open [15:14]		Phase Offset Word 0 [13:8]						0x00	
	[7:0]	Phase Offset Word 0 [7:0]									0x00
Amplitude Control Register (ACR) (0x06)	[23:16]	Amplitude ramp rate [23:16]									N/A
	[15:8]	Increment/decrement step size [15:14]		Open	Amplitude multiplier enable	Ramp-up/down enable	Load ARR at I/O_UPDATE	Amplitude scale Factor [9:8]		0x13	
	[7:0]	Amplitude scale factor [7:0]									0xFF
* Linear Sweep Ramp Rate (LSRR) (0x07)	[15:8]	Falling sweep ramp rate (FSRR) [15:8]									N/A
	[7:0]	Rising sweep ramp rate (RSRR) [7:0]									N/A
* LSR Rising Delta Word (RDW) (0x08)	[31:24]	Rising delta word [31:24]									N/A
	[23:16]	Rising delta word [23:16]									N/A
	[15:8]	Rising delta word [15:8]									N/A
	[7:0]	Rising delta word [7:0]									N/A
* LSR Falling Delta Word (FDW) (0x09)	[31:24]	Falling delta word [31:24]									N/A
	[23:16]	Falling delta word [23:16]									N/A
	[15:8]	Falling delta word [15:8]									N/A
	[7:0]	Falling delta word [7:0]									N/A

** The clear phase accumulator bit is set to Logic 1 after a master reset. It self-clears or is set to Logic 0 when an I/O update is asserted.

* There are four sets of channel registers and profile registers, one per channel. The addresses of all channel registers and profile registers are the same for each channel. The channel enable bits (Control Register 0, CSR [7:4]) determine if the channel registers and/or profile registers of each channel are written to or not.

Profile Register Map

For clarity, only the MSB byte is shown for each Channel Word register.

Register Name	Bit Range	Bit 7 (MSB)	Bit 6	Bit 5	Bit 4	Bit 3	Bit 2	Bit1	Bit 0 (LSB)	Default Value
Channel Word 1 (CW1) (0x0A)	[31:0]	Frequency tuning word [31:0] or Phase word [31:18] or Amplitude word [31:22]								N/A
Channel Word 2 (CW2) (0x0B)	[31:0]	Frequency tuning word [31:0] or Phase word [31:18] or Amplitude word [31:22]								N/A
Channel Word 3 (CW3) (0x0C)	[31:0]	Frequency tuning word [31:0] or Phase word [31:18] or Amplitude word [31:22]								N/A
Channel Word 4 (CW4) (0x0D)	[31:0]	Frequency tuning word [31:0] or Phase word [31:18] or Amplitude word [31:22]								N/A
Channel Word 5 (CW5) (0x0E)	[31:0]	Frequency tuning word [31:0] or Phase word [31:18] or Amplitude word [31:22]								N/A
Channel Word 6 (CW6) (0x0F)	[31:0]	Frequency tuning word [31:0] or Phase word [31:18] or Amplitude word [31:22]								N/A
Channel Word 7 (CW7) (0x10)	[31:0]	Frequency tuning word [31:0] or Phase word [31:18] or Amplitude word [31:22]								N/A
Channel Word 8 (CW8) (0x11)	[31:0]	Frequency tuning word [31:0] or Phase word [31:18] or Amplitude word [31:22]								N/A
Channel Word 9 (CW9) (0x12)	[31:0]	Frequency tuning word [31:0] or Phase word [31:18] or Amplitude word [31:22]								N/A
Channel Word 10 (CW10) (0x13)	[31:0]	Frequency tuning word [31:0] or Phase word [31:18] or Amplitude word [31:22]								N/A
Channel Word 11 (CW11) (0x14)	[31:0]	Frequency tuning word [31:0] or Phase word [31:18] or Amplitude word [31:22]								N/A
Channel Word 12 (CW12) (0x15)	[31:0]	Frequency tuning word [31:0] or Phase word [31:18] or Amplitude word [31:22]								N/A
Channel Word 13 (CW13) (0x16)	[31:0]	Frequency tuning word [31:0] or Phase word [31:18] or Amplitude word [31:22]								N/A
Channel Word 14 (CW14) (0x17)	[31:0]	Frequency tuning word [31:0] or Phase word [31:18] or Amplitude word [31:22]								N/A
Channel Word 15 (CW15) (0x18)	[31:0]	Frequency tuning word [31:0] or Phase word [31:18] or Amplitude word [31:22]								N/A

Each channel word register has a capacity of 32 bits (only 8 shown above).

If phase or amplitude is stored in the channel word registers, it must be first MSB aligned per the bit range.

File System

Once created, DDSScripts can be downloaded to the filesystem on the Synthesiser (they can only be committed to the AD9959 from the file system, they cannot be executed directly).

Create a DDSScriptDownload object initialised from the DDSScript and the attached iMS, then call the .Program() function to transfer the contents. The function parameters assign a file name (max 8 chars) to the script stored in the Filesystem, and indicate whether it should be executed at power-up (DEFAULT) or not (NON_DEFAULT). This second argument is optional, if not given, it will be set to NON_DEFAULT. Note that only one script in the Filesystem can be set to DEFAULT.